

Locking Elements

TAS 8006

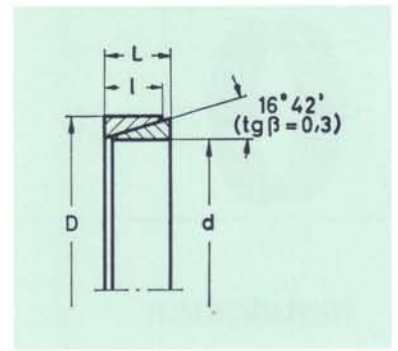

Locking Element designation for shaft diameter $d = 70$ mm:
Locking Element TAS 8006/070/079

$d \times D$	L	l	A_t	F_0	$F_{A'}$ (valid for $p \approx 100$ N/mm ²)	T or F_{ax}	1	2	3	4	Weight	d_1	D_1	
mm	mm	mm	mm ²	N	N	Nm	X Elements mm				kg	mm	mm	
* 6 x 9	4,5	3,7	69	-	3240	2,16	720	2	2	3	3	0,00118	6,1	8,9
* 7 x 10	4,5	3,7	80	-	3780	2,94	840	2	2	3	3	0,00136	7,1	9,9
* 8 x 11	4,5	3,7	90	-	4300	3,84	960	2	2	3	3	0,00151	8,1	10,9
9 x 12	4,5	3,7	105	7600	5700	5,7	1270	2	2	3	3	0,00166	9,1	11,9
10 x 13	4,5	3,7	116	6950	6300	7	1400	2	2	3	3	0,00182	10,1	12,9
12 x 15	4,5	3,7	139	6950	7500	10	1670	2	2	3	3	0,00214	12,1	14,9
13 x 16	4,5	3,7	151	6450	8150	11,8	1810	2	2	3	3	0,00226	13,1	15,9
14 x 18	6,3	5,3	233	11200	12600	19,6	2800	3	3	4	5	0,00487	14,1	17,9
15 x 19	6,3	5,3	250	10750	13500	22,5	3000	3	3	4	5	0,00526	15,1	18,9
16 x 20	6,3	5,3	266	10100	14400	25,5	3190	3	3	4	5	0,00545	16,1	19,9
17 x 21	6,3	5,3	283	9550	15300	28,9	3400	3	3	4	5	0,0058	17,1	20,9
18 x 22	6,3	5,3	300	9100	16200	32,4	3600	3	3	4	5	0,00612	18,1	21,9
19 x 24	6,3	5,3	316	12600	17100	36	3790	3	3	4	5	0,00782	19,2	23,8
20 x 25	6,3	5,3	333	12050	18000	40	4000	3	3	4	5	0,00817	20,2	24,8
22 x 26	6,3	5,3	366	9050	19800	48	4400	3	3	4	5	0,00724	22,2	25,8
24 x 28	6,3	5,3	400	8350	21600	58	4800	3	3	4	5	0,00792	24,2	27,8
25 x 30	6,3	5,3	416	9900	22500	62	5000	3	3	4	5	0,0101	25,2	29,8
28 x 32	6,3	5,3	466	7400	25200	78	5600	3	3	4	5	0,00918	28,2	31,8
30 x 35	6,3	5,3	499	8500	27000	90	6000	3	3	4	5	0,012	30,2	34,8
32 x 36	6,3	5,3	533	7850	28800	102	6400	3	3	4	5	0,01	32,2	35,8
35 x 40	7	6	659	10100	35600	138	7900	3	3	4	5	0,017	35,2	39,8
36 x 42	7	6	678	11600	36600	147	8200	3	3	4	5	0,02	36,2	41,8
38 x 44	7	6	716	11000	38700	163	8600	3	3	4	5	0,021	38,2	43,8
40 x 45	8	6,6	829	13800	45000	199	9950	3	4	5	6	0,023	40,2	44,8
42 x 48	8	6,6	870	15600	47000	219	10400	3	4	5	6	0,028	42,2	47,8
45 x 52	10	8,6	1215	28200	66000	328	14600	3	4	5	6	0,042	45,2	51,8
48 x 55	10	8,6	1296	24600	70000	373	15600	3	4	5	6	0,045	48,2	54,8
50 x 57	10	8,6	1350	23500	73000	405	16200	3	4	5	6	0,047	50,2	56,8
55 x 62	10	8,6	1485	21800	80000	490	17800	3	4	5	6	0,05	55,2	61,8
56 x 24	12	10,4	1829	29400	99000	615	22000	3	4	5	7	0,067	56,2	63,8
60 x 68	12	10,4	1959	27400	106000	705	23500	3	4	5	7	0,072	60,2	67,8
63 x 71	12	10,4	2057	26300	111000	780	24800	3	4	5	7	0,077	63,2	70,8
65 x 73	12	10,4	2123	25400	115000	830	25600	3	4	5	7	0,079	65,2	72,8
70 x 79	14	12,2	2682	31000	145000	1120	32000	3	5	6	7	0,111	70,3	78,7
71 x 80	14	12,2	2720	31000	147000	1160	32600	3	5	6	7	0,113	71,3	79,7
75 x 84	14	12,2	2873	34600	155000	1290	34400	3	5	6	7	0,12	75,3	83,7
80 x 91	17	15	3768	48000	203000	1810	45000	4	5	6	8	0,188	80,3	90,7
85 x 96	17	15	4004	45600	216000	2040	48000	4	5	6	8	0,2	85,3	95,7
90 x 101	17	15	4239	43400	229000	2290	51000	4	5	6	8	0,216	90,3	100,7
95 x 106	17	15	4475	41200	242000	2550	54000	4	5	6	8	0,224	95,3	105,7
100 x 114	21	18,7	5872	60700	317000	3520	70000	4	6	7	9	0,38	100,3	113,7
110 x 124	21	18,7	6459	66000	349000	4250	77000	4	6	7	9	0,41	110,3	123,7
120 x 134	21	18,7	7046	60200	380000	5050	84000	4	6	7	9	0,452	120,3	133,7
130 x 148	28	25,3	10328	96200	558000	8050	124000	5	7	9	11	0,847	130,4	147,6
140 x 158	28	25,3	11122	89000	600000	9350	134000	5	7	9	11	0,91	140,4	157,6
150 x 168	28	25,3	11916	84500	643000	10700	143000	5	7	9	11	0,967	150,4	167,6
160 x 178	28	25,3	12711	78500	686000	12200	152500	5	7	9	11	1,023	160,4	177,6
170 x 191	33	30	16014	117500	865000	16300	192000	6	8	10	12	1,5	170,5	190,5
180 x 201	33	30	16956	111200	916000	18300	204000	6	8	10	12	1,58	180,5	200,5
190 x 211	33	30	17898	105000	966000	20400	214000	6	8	10	12	1,68	190,5	210,5
200 x 224	38	34,8	21854	134000	1180000	26200	262000	6	8	11	13	2,32	200,6	223,4
210 x 234	38	34,8	22947	127000	1239000	28900	275000	6	8	11	13	2,45	210,6	233,4
220 x 244	38	34,8	24040	122000	1298000	31700	288000	6	8	11	13	2,49	220,6	243,4
230 x 257	43	39,5	28527	165000	1540000	39400	342000	6	9	12	14	3,38	230,6	256,4
240 x 267	43	39,5	29767	157500	1610000	43000	358000	6	9	12	14	3,52	240,6	266,4
250 x 280	48	44	34700	190000	1870000	52000	415000	7	10	13	16	4,68	250,8	279,2
260 x 290	48	44	36100	182000	1950000	56500	435000	7	10	13	16	4,82	260,8	289,2
270 x 300	48	44	37500	177000	2030000	61000	450000	7	10	13	16	4,94	270,8	299,2
280 x 313	53	49	43100	206000	2330000	72500	520000	7	11	14	17	6,27	280,8	312,2
290 x 323	53	49	44600	222000	2410000	77500	535000	7	11	14	17	6,5	290,8	332,2
300 x 333	53	49	46200	214000	2490000	83000	555000	7	11	14	17	6,74	300,8	322,2
320 x 360	65	59	59300	292000	3200000	114000	710000	10	15	20	25	10,9	321	359
340 x 380	65	59	63000	272000	3400000	128500	755000	10	15	20	25	11,5	341	379
360 x 400	65	59	66700	258000	3600000	144000	800000	10	15	20	25	12,2	361	399
380 x 420	65	59	70400	269000	3800000	160500	845000	10	15	20	25	12,8	381	419
400 x 440	65	59	74200	256000	4000000	178000	890000	10	15	20	25	13,5	401	439
420 x 460	65	59	77800	244000	4200000	196000	935000	10	15	20	25	14,1	421	459
440 x 480	65	59	81500	234000	4400000	215000	980000	10	15	20	25	14,7	441	479
460 x 500	65	59	85300	224000	4600000	235000	1020000	10	15	20	25	15,4	461	499
480 x 520	65	59	89000	239000	4800000	256000	1070000	10	15	20	25	16	481	519
500 x 540	65	59	92700	229000	5000000	278000	1110000	10	15	20	25	16,6	501	539

* Generally slit



Installation and removal instructions for Locking Elements TAS 8006

Installation

Since the force is transmitted by contact pressure and friction between functional surfaces, condition of contact surfaces and proper tightening of the locking screws are of great importance (see point1).

1. All contact surfaces, including screw threads and screw head bearing surfaces must be clean and slightly oiled. In this condition, the shaft, hub and Locking Elements are to be assembled. Locking Elements, clamp flange and spacer sleeves must fit loosely.
2. Tighten locking screws lightly and align hub.
3. Tighten screws evenly in diametrically opposite sequence and do this in two or three

stages. After tightening of the locking screws is completed, the clamp flange should not make contact with the hub face at any point.

4. Check the torque of the locking screws in same sequence as they were tightened. Assembly is completed when no screw can be turned any more by the tightening torque.

Important: Locking screws must be sufficiently oiled.

Do not use oils containing Molybdenum Disulphide.

Item 1: Spacer sleeve
Item 2: Locking Element
Item 3: Clamp flange
Item 4: Locking screw

dG	6.9 T _A		8.8 T _A		10.9 T _A		12.9 T _A	
	Nm	ft-lbs	Nm	ft-lbs	Nm	ft-lbs	Nm	ft-lbs
M 6	8,5	6.15	10	7.23	14	10.13	17	12.30
M 8	21	15.19	25	18.08	35	25.32	41	29.65
M 10	41	29.65	49	35.44	70	50.63	83	60.00
M 12	72	52.08	86	62.20	125	90.41	145	104.88
M 14	115	83.13	135	97.65	190	137.43	230	166.36
M 16	180	130.19	210	151.89	295	213.37	355	256.77
M 18	245	177.21	290	209.76	405	292.94	485	350.80
M 20	345	249.54	410	296.55	580	419.51	690	499.08
M 22	465	336.33	550	397.82	780	564.17	930	672.67
M 24	600	433.98	710	513.54	1000	723.30	1200	867.96

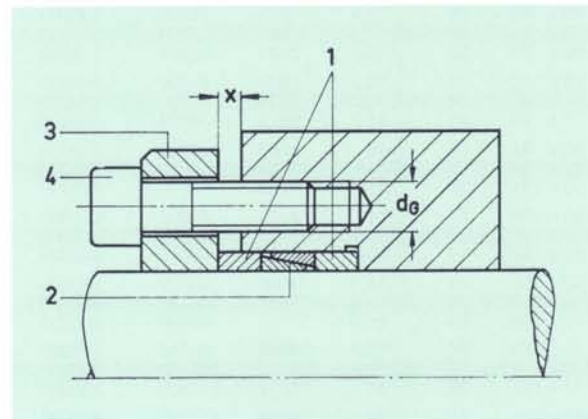

Removal

1. Clean connection area.
2. Loosen locking screws in several stages and in diametrically opposite sequence.
3. Now the loosened connection can be re-adjusted or dis-assembled..

If the Locking Elements should jam, loosen hub by means of light blows or tapping with a hammer. Use of pulling devices prior to loosening of the Locking Elements will cause damage to the shaft seat.