

Verwendete Formelzeichen

d	[mm]	Nenndurchmesser der Schrumpfscheibe
d_w	[mm]	Wellendurchmesser
M_{max}	[Nm]	maximal übertragbares Moment
D	[mm]	Außendurchmesser
l	[mm]	Länge des Innenrings
e	[mm]	Überstand
H	[mm]	Breite der Schrumpfscheibe
A	[mm]	Teilkreisdurchmesser
B	[mm]	Ansatzdurchmesser
M_A	[Nm]	erforderliches Anzugsmoment der Spanschrauben
Z		Anzahl der Spanschrauben
S		Größe der Spanschrauben
n_{max}	[min ⁻¹]	zulässige Drehfrequenz
p_N	[N/mm ²]	mittlerer Anpressdruck auf die Nabe
I	[kgm ²]	Trägheitsmoment

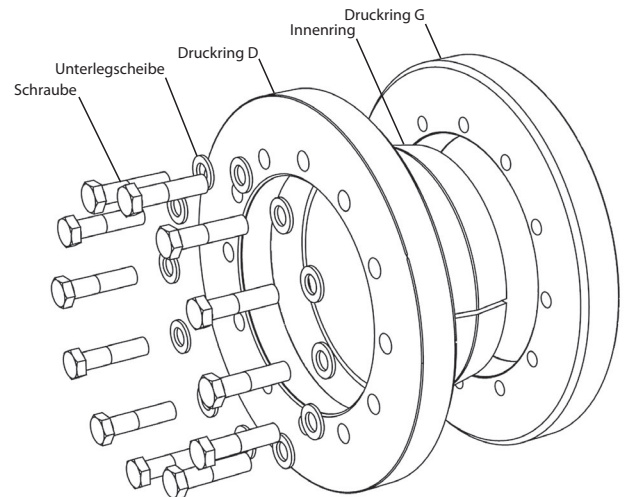

Ausführung der Schrumpfscheiben

$d < 115$ - Druckringe verzinkt - ohne Unterlegscheiben

$d \geq 110$ - Druckringe lackiert - mit Unterlegscheiben

Maße H & e im ungespannten Zustand

Als Standard kommen Sechskantschrauben zum Einsatz.
Auf Wunsch liefern wir alle Größen auch mit Innen-6kt.-Schrauben.
(Siehe Bestellangaben)

Abweichung vom Standard Wellendurchmesser d_w

> mm	≤ mm	minimal - mm	maximal + mm
10	30	-1	1
30	50	-3	2
50	140	-5	5
140	180	-10	5
180	320	-15	10
320	500	-20	10
500	700	-30	20
700	820	-40	20

Mindest-Dehngrenze $R_{p0,2}$	N/mm ²
Vollwelle	350
Nabe	450

$$M = M_{max(Katalog)} \left(\frac{d_{W(soll)}}{d_{W(Katalog)}} \right)^2$$

(siehe Grundlagen - Berechnung)

Bestellangabe: TAS 3081 - d (z.B.: TAS 3081-200 ... weitere Größen auf Anfrage)
mit Inbus: TAS 3081 - d - Inbus (z.B.: TAS 3081-200-Inbus)

3081

Standard-Reihe verstärkt

<i>d</i> mm	<i>d_w</i> mm	<i>M_{max}</i> Nm	<i>D</i> mm	<i>l</i> mm	<i>e</i> mm	<i>H</i> mm	<i>A</i> mm	<i>B</i> mm	<i>M_A</i> Nm	<i>Z</i> Stk	<i>S</i>	<i>DIN</i>	<i>Klasse</i>	<i>n_{max}</i> min ⁻¹	<i>p_N</i> N/mm ²	<i>I</i> kgm ²	<i>Gewicht</i> kg
14	11	48	37	9	1,5	12	24	15	4	3	M 4 x 10	933	12.9	15400	344	0,000137	0,07
30	25	520	60	16	2,75	21,5	44	32	8	6	M 5 x 18	931	12.9	9500	300	0,001687	0,30
36	30	780	72	18	2,75	23,5	52	38	14	5	M 6 x 20	933	12.9	7900	271	0,0003888	0,48
38	31	1100	80	20	3	26	56	41	14	7	M 6 x 25	933	12.9	7100	324	0,0006569	0,67
40	32	910	75	19	2,75	24,5	57	43	14	6	M 6 x 20	933	12.9	7600	277	0,0004967	0,55
50	40	1500	90	22	3	28	70	53	14	8	M 6 x 25	933	12.9	6300	255	0,0010998	0,83
55	45	1800	100	23	3,75	30,5	75	58	14	8	M 6 x 25	933	12.9	5700	222	0,0017909	1,1
62	50	2600	110	23	3,75	30,5	86	66	14	10	M 6 x 25	933	12.9	5200	246	0,0025909	1,3
68	55	2700	115	23	3,75	30,5	86	72	14	10	M 6 x 25	933	12.9	4900	225	0,0031236	1,4
75	60	4400	138	25	3,75	32,5	100	79	35	7	M 8 x 30	933	12.9	4100	272	0,0070923	2,3
80	65	4900	145	25	3,75	32,5	100	84	35	7	M 8 x 30	933	12.9	3900	255	0,0085703	2,5
90	70	7200	155	30	4,5	39	114	94	35	10	M 8 x 35	931	12.9	3600	269	0,0132516	3,3
100	75	8800	170	34	5	44	124	104	35	12	M 8 x 35	931	12.9	3300	257	0,0213950	4,4
110	80	10800	185	39	5,5	50	136	114	69	9	M 10 x 40	931	12.9	3000	243	0,0347437	6,0
115	80	11400	200	40	5	50	150	124	69	10	M 10 x 40	931	12.9	2800	252	0,0485678	7,3
120	85	11700	200	40	5	50	150	124	69	10	M 10 x 40	931	12.9	2800	241	0,0476000	7,0
125	90	15900	215	42	6	54	160	134	69	12	M 10 x 40	931	12.9	2600	265	0,0672619	8,7
140	100	21700	230	46	7,25	60,5	175	146	120	10	M 12 x 45	931	12.9	2400	263	0,0996875	11
155	110	28900	265	50	7,25	64,5	192	165	120	12	M 12 x 50	931	12.9	2100	262	0,1885000	16
165	120	46400	290	56	7,5	71	210	175	290	8	M 16 x 55	931	12.9	1900	303	0,3061438	22
175	130	51200	300	56	7,5	71	220	185	290	8	M 16 x 55	931	12.9	1900	286	0,3467969	23
185	140	70700	330	71	7,5	86	236	195	290	10	M 16 x 70	931	12.9	1700	266	0,6261719	35
195	150	94900	350	71	7,5	86	246	210	290	12	M 16 x 70	931	12.9	1600	303	0,8026250	40
200	155	97700	350	71	7,5	86	246	210	290	12	M 16 x 70	931	12.9	1600	296	0,7921875	39
220	165	124000	370	88	8	104	270	230	290	15	M 16 x 80	931	12.9	1500	271	1,1813	51
240	180	171000	405	92	8,5	109	295	248	570	12	M 20 x 80	931	12.9	1400	296	1,7730	64
245	185	175000	410	95	8	111	298	251	570	12	M 20 x 80	931	12.9	1300	281	1,9105	67
260	190	203000	440	103	8,5	120	321	268	570	14	M 20 x 90	931	12.9	1300	285	2,7426	84
280	210	266000	460	114	10	134	346	288	570	16	M 20 x 100	931	12.9	1200	273	3,5888	99
300	230	340000	485	122	10	142	364	308	570	18	M 20 x 100	931	12.9	1100	268	4,6751	115
320	240	386000	520	122	10	142	386	328	570	20	M 20 x 100	931	12.9	1100	279	6,1978	133
340	250	474000	570	134	11	156	408	348	570	24	M 20 x 110	931	12.9	1000	287	10,08	183
350	270	539000	580	140	11	162	432	358	570	24	M 20 x 110	931	12.9	980	267	11,07	193
360	290	613000	590	140	11	162	432	368	570	24	M 20 x 110	931	12.9	970	259	11,76	197
380	300	750000	645	144	12	168	458	387	980	20	M 24 x 120	931	12.9	880	287	17,86	255
390	310	824000	660	144	12	168	468	397	980	21	M 24 x 120	931	12.9	860	294	19,54	266
400	320	853000	680	144	12	168	480	407	980	21	M 24 x 120	931	12.9	840	286	22,10	284
420	340	1052000	690	164	12	188	504	427	980	24	M 24 x 130	931	12.9	830	274	25,94	318
440	350	1054000	750	177	12,5	202	527	447	980	24	M 24 x 140	931	12.9	760	242	39,13	414
460	370	1331000	770	177	12,5	202	547	468	980	28	M 24 x 140	931	12.9	740	270	43,04	428
480	390	1523000	800	188	12,5	213	570	488	980	30	M 24 x 140	931	12.9	710	261	52,77	485
500	410	1691000	850	188	12,5	213	590	508	1450	24	M 27 x 150	931	12.9	670	263	68,08	560
530	440	2314000	900	215	12,5	240	620	538	1450	30	M 27 x 180	931	12.9	630	272	93,54	686
560	460	2554000	950	215	12,5	240	650	568	1450	32	M 27 x 180	931	12.9	600	274	116	763
590	480	2967000	980	235	15	265	685	600	1450	36	M 27 x 180	931	12.9	580	268	142	869
620	510	3370000	1020	235	15	265	715	630	1450	38	M 27 x 180	931	12.9	560	269	166	931

3081

Standard-Reihe verstärkt

<i>d</i> mm	<i>d_w</i> mm	<i>M_{max}</i> Nm	<i>D</i> mm	<i>l</i> mm	<i>e</i> mm	<i>H</i> mm	<i>A</i> mm	<i>B</i> mm	<i>M_A</i> Nm	<i>Z</i> Stk	<i>S</i>	<i>DIN</i>	<i>Klasse</i>	<i>n_{max}</i> min ⁻¹	<i>p_N</i> N/mm ²	<i>I</i> kgm ²	<i>Gewicht</i> kg
660	540	4329000	1100	260	15	290	760	670	1950	38	M 30 x 200	931	12.9	520	278	246	1195
700	580	4980000	1200	260	15	290	800	710	1950	40	M 30 x 200	931	12.9	470	276	354	1466
720	600	5456000	1230	260	15	290	820	730	1950	42	M 30 x 200	931	12.9	460	282	390	1535
750	620	5844000	1230	280	17,5	315	855	762	1950	44	M 30 x 220	931	12.9	460	263	420	1619
800	660	6475000	1310	280	17,5	315	905	812	1950	46	M 30 x 220	931	12.9	430	258	540	1833
850	700	7443000	1330	310	17,5	345	965	862	1950	50	M 30 x 250	931	12.9	430	238	604	1938
900	740	8180000	1400	310	17,5	345	1015	912	1950	52	M 30 x 250	931	12.9	400	234	738	2130
950	780	10005000	1550	340	20	380	1075	962	3300	42	M 36 x 260	931	12.9	370	234	1285	3111
1000	820	12541000	1620	340	20	380	1125	1012	3300	50	M 36 x 260	931	12.9	350	265	1526	3369