

**TAS**  
**SCHÄFER**



# Flange Coupling

Connecting flange, rigid connection



# Description of function FK

## Rigid flange coupling with three-parted shrink disc of the type TAS 30..

The main function of the rigid flange coupling (FK) is the safe and backlash-free connection of two shafts by means of friction. For example, between a drive shaft and an agitator shaft. Flange couplings are directly separable at the flanges. The used shrink discs generate a backlash-free connection by pressing the flange-hubs onto the shafts. This connection is mainly used to transmit torque.

The shrink discs do not transmit any forces and/or moments between the shafts and hubs, they just provide the necessary forces. They are not in the flow of forces.

It is installed by sliding the flanges onto the shaft ends and subsequent tightening of the shrink disc. Thereafter the flanges are connected by bolting.

The rigid flange couplings are supplied ready for installation.

To achieve proper operation and a sufficiently high coefficient of friction, the contact surfaces between the shaft extensions and flange-hubs, as well as the contact surfaces of the flanges, must be free of grease, dry and clean. The functional surfaces of the shrink disc, threads and head rests of the screws are provided at the factory with lubricant. The contact surfaces between the flange-hubs and shrink discs are oiled.

A detailed installation manual is available on the Internet.

### Product data

#### Data sheets

- Contact us if a data sheet for an individual product is required.

For CAD data of flange couplings, contact us directly, please.

**Rolf Gertner**  
rolf.gertner@tas-schaefer.de

or

**Mike Kemper**  
mike.kemper@tas-schaefer.de

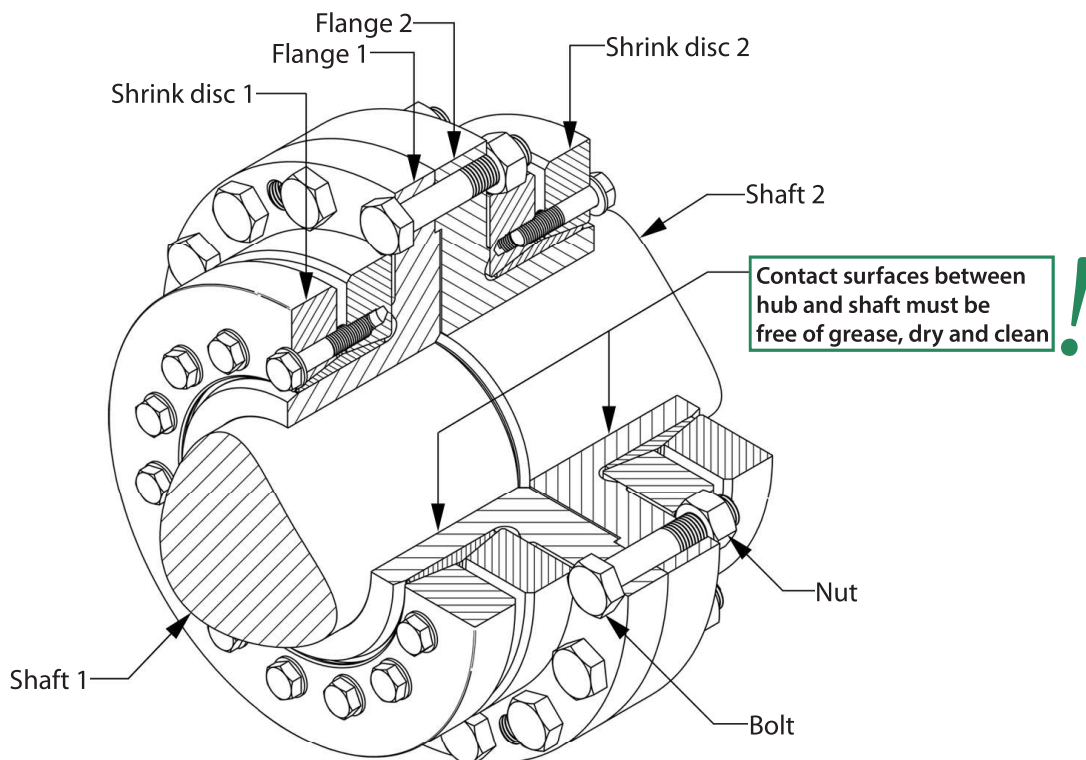

# Basics - Calculation FK

## Advantages and differences to other systems

- **Use of shrink discs / flow of forces**

Due to the use of shrink discs, the forces and moments are transferred directly between the shaft and flange. In comparison with internal clamping systems the achievable runout accuracy is higher.

- **Pursue the same diameter - but an adaptation to different diameters is also possible**

Basically the target should be to connect shaft ends of the same size. With larger deviations the flange-hubs can be adapted for the different diameters. This is done by using different shrink discs.

- **Tightening torque of the clamping screws**

When using different shrink discs and shaft diameters, the tightening torque and therefore the clamping forces of the shrink discs are adjustable. For example, this is also possible with soft shaft materials and reduces, if required, the stresses in the components.

- **Positioning**

The cylindrical connection, as well as the used clearance, allows an easy and precise positioning of the flanges on the shaft ends. During the clamping process there is no more shift.

- **Short length (B version)**

The design „B“, with clamping the shrink discs through the flange face, provides a very short mounting length, as there is no extra space needed behind the coupling.

- **No hydraulic necessary**

A hydraulic expansion of the hubs is not necessary for mounting.

- **No heating necessary**

There is no need for expansion of the hubs by heating. To increase the clearance between the shaft and flange, a slight warming is possible.

- **Shafts with keyways**

The couplings can be used on shafts with keyways. As far as possible, the keyways should be closed.

- **Tolerances and surfaces**

The values found in the product data, are based on surface quality and tolerances, according to the table below. These values are given as recommendations.

Higher values for the surface roughness reduce the transmissible torque and promote unwanted settling.

Larger clearance also reduces the transmissible torque and increases stresses in the flange-hub.

**If you have different shaft tolerances, please let us know. Then we can adjust the bores in the flanges accordingly!**

Recommended tolerances and surface roughness

>	≤	FS <sub>max</sub> mm	Clearance Hub / Shaft	Rz µm
9	18	0,022	H6/h6	10
18	30	0,026	H6/h6	10
30	50	0,032	H6/h6	10
50	80	0,049	H7/h6	10
80	120	0,057	H7/h6	16
120	150	0,065	H7/h6	16
150	180	0,079	H7/g6	16
180	250	0,090	H7/g6	16
250	315	0,101	H7/g6	16
315	400	0,111	H7/g6	16
400	500	0,123	H7/g6	25
500	630	0,136	H7/g6	25
630	800	0,154	H7/g6	25
800	1000	0,172	H7/g6	25

# Basics - Calculation FK

The calculation of the values, given in the catalogue, are based on the following assumptions and simplifications:

## Distinction flange connection / shrink disc

Due to the design, the transmissible forces and torque, are to look separately for the shrink disc and the flange. While the shrink disc provides clamping forces only, the transmissible forces and torque must be accommodated by the flange. This results in different values for shrink connection and flange.

## Transmissible torque at the shrink disc

A shrink disc connection is capable of transmitting torque, bending moment and axial force. Substituted, the transmissible torque  $M_{\max}$  is specified in the product data. If such loads occur simultaneously then they must be added vectorially to the resultant moment  $M_{\text{res}}$ . The formula below applies to the resulting moment:

$$M_{\text{res}} \leq M_{\max}$$

At different load cases, they must be individually checked against  $M_{\max}$ !

$M_{\text{res}}$  is determined for combined loads as follows:

$$M_{\text{res}} = \sqrt{M_T^2 + 2M_B^2 + (F_{AX} \frac{d_W}{2})^2}$$

with  $M_B \leq 0,3 M_{\max}$   
as the limit \* for the bending moment

\*In principle, the maximum bending moment corresponds to the maximum transmittable torque. The limitation to  $0,3 M_{\max}$  is due to the change of the surface pressure at the edges of the connection.  
(This information applies to the shrink connection only!)

## This results in the following relationships:

### Nur Drehmoment:

The maximum torque is equivalent to  $M_{\max}$ .

### Nur Biegemoment:

The maximum static bending moment corresponds to  $0,4 M_{\max}$ .

## Axial force only :

The maximum axial force is  $M_{\max} \frac{2}{d_W}$

In addition, the load on the flange bolting connection must be taken into account

Transmissible forces and torque at the flange connection

The bolt connection of the flanges is also based on friction. The torque is transmitted via this connection.

Whereas the torque capacity usually corresponds to, or is higher than that of the shrink connection it is any transmissible bending moment which must be particularly considered.

Bending influences the bolt connections and the flange itself. The static load case usually corresponds to the transmissible bending moment of the shrink connection, the bending moment capacity is however lower in the dynamic load and will be determined for each individual case by us (refer to the Product questionnaire).

The same applies to axial loads, as they are transmitted directly by the bolt connection of the flanges.

## Static and dynamic load

For some applications, a static review of the coupling is sufficient. The clamping forces of the shrink connection are static. Non cyclic torques and/or axial forces can also be considered as static loads. Rotating bending has to be considered as a dynamic load and the coupling must be calculated accordingly. Therefore it is also essential to specify the actual occurring load cases.

## Shaft and hub calculation

The flange-hub will be deformed due to the applied clamping force. Shaft stiffness and surface finish should be considered in addition to the clearance between shaft and hub. Stiffness can be ignored for solid shafts, but for hollow shafts (see „Bore in the shaft (hollow shaft)“) there is higher deformation and thus higher stresses in the components. This must be considered in addition to other loads.

The stresses in the hub can be determined by various hypotheses, such as GEH. A discussion and analysis of results is not made here because only a very limited range of static applications could be covered. Various calculation methods for different cases can be found in engineering literature or using specialised software. Often only a calculation via FEA will give reliable results for complex geometry

## Notch effect

Generally there is a notch effect on the components caused by the radial pressure of the pressure ring. This depends mainly on the applied pressure. The notch effect is generally higher on the hub than on the shaft, because the pressure ring is directly pressed onto the hub, while the stresses are distributed through the hub before reaching the shaft. The notch factors range from 2,5 to 3,5 for the hub and between 1,5 and 2 for the shaft. This can be mitigated by suitable design features, such as relief notches.

Some standards provide the possibility for a notch factor to be determined by a fit pairing (interference fit) for a shrink-connection. A similar method can also be used for such shrink connections. To this end an oversize can be calculated from the applied surface pressures. As a result a matching fit pair can be determined and thus a resultant notch factor found.

## Bore in the shaft (hollow shaft)

A large bore  $d_B$  in the shaft or the use of a hollow shaft, reduces the stiffness of the shaft against radial pressure. This leads to a decrease in pressure  $p_W$ , a reduced transmissible torque  $M$ , a contraction  $\Delta d_B$  within the shaft and an increase of stresses in these components. Basically, a bore should not be greater than  $0,3 d_W$ .

# Rigid Flange Coupling FK/FKB

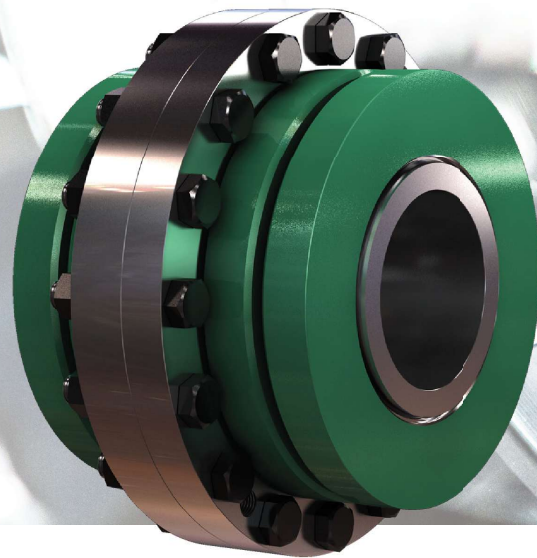
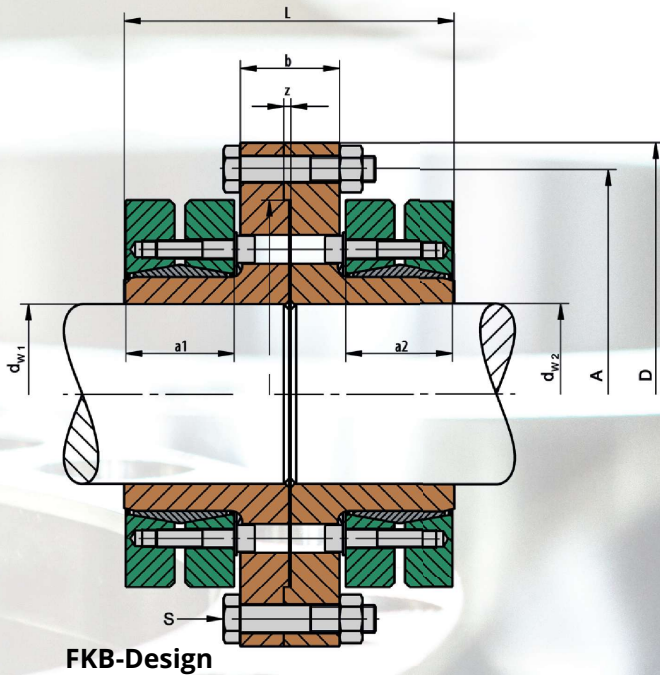

## Used symbols

<i>FK</i>		Nominal size
$d_{w1}$ & $d_{w2}$ [mm]		Shaft diameters
$M_{t,max}$ [Nm]		Maximal transmittable torque (depends on used shrink disc and $d_w$ )
<i>A</i> [mm]		Pitch circle diameter
<i>D</i> [mm]		Outer diameter
$D_z$ [mm]		Diameter of the flange centering
<i>L</i> [mm]		Width of the flange coupling
<i>a</i> [mm]		Width of the shrink disc
<i>b</i> [mm]		Thickness of flange
<i>z</i> [mm]		Depth of the centering
<i>I</i> [kgm <sup>2</sup> ]		Moment of inertia
		<b>Bolts</b>
<i>Z</i>		Number
<i>S</i>		Size
$M_A$ [Nm]		Required tightening torque

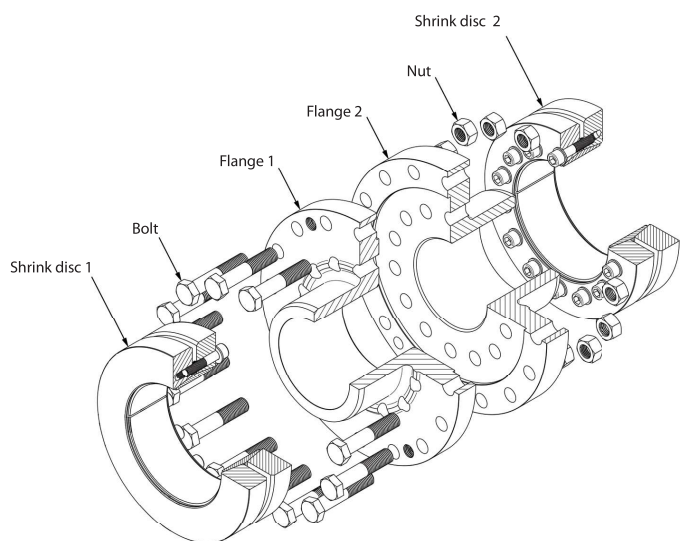

# Rigid Flange Coupling FK/FKB

FK	d <sub>w</sub> mm	M <sub>t,max</sub> Nm	Shrink disc		Dimensions							Flange bolts			I kgm <sup>2</sup>	Weight kg
			Type 3071-d	M <sub>A</sub> Nm	A mm	D mm	D <sub>z</sub> mm	L mm	a mm	b mm	z mm	Z Stk	S	M <sub>A</sub> Nm		
75	75	7300	100	30	210	240	170	136	44	44	4	6	M 16 x 70	210	0,165499	26
90	90	13100	125	59	265	305	215	160	54	48	5	6	M 20 x 80	420	0,487699	48
100	100	17900	140	100	286	340	230	190	64	56	5	5	M 24 x 90	720	0,829143	63
120	120	38700	165	250	356	400	300	228	75	72	5	8	M 24 x 110	720	2,126131	120
130	130	42600	175	250	356	400	300	228	75	72	5	8	M 24 x 110	720	2,246611	120
150	150	79500	195	250	420	475	350	278	90	90	6	10	M 30 x 130	1450	5,408399	215
165	165	103000	220	250	440	510	370	314	108	90	6	14	M 30 x 130	1450	7,692146	270
180	180	144000	240	490	475	540	405	322	113	88	6	16	M 30 x 130	1450	10,247074	310
200	200	193000	<sup>(1)</sup> 260	490	500	560	430	368	125	110	8	16	M 30 x 150	1450	14,889123	395
220	220	251000	280	490	530	590	460	392	139	104	8	18	M 30 x 150	1450	18,392262	445
240	240	318000	300	490	555	615	485	408	147	104	8	20	M 30 x 150	1450	22,627586	500
260	260	435000	340	490	640	710	570	450	161	118	8	24	M 30 x 160	1450	45,880687	780
290	290	519000	360	490	660	720	590	450	167	106	8	24	M 30 x 150	1450	76,117692	790
310	310	697000	390	840	735	805	660	484	180	114	8	28	M 30 x 160	1450	81,558246	1060
340	340	891000	420	840	770	835	690	530	198	122	10	30	M 30 x 160	1450	102,442438	1230
380	380	1198000	460	840	845	920	770	556	208	128	10	35	M 30 x 170	1450	166,038502	1420
410	410	1431000	500	1250	940	1030	850	618	225	156	12	32	M 36 x 200	2400	283,051874	2200
440	440	1961000	530	1250	1000	1100	900	696	258	160	14	36	M 36 x 200	2400	382,170457	2680
470	470	2397000	590	1250	1080	1180	980	744	280	164	14	40	M 36 x 200	2400	553,092493	3340
500	500	2742000	620	1250	1110	1210	1020	744	280	164	14	42	M 36 x 200	2400	638,288490	3620

<sup>(1)</sup> 3071.4

## How to order (product identification)

T A S F K B S - 0 9 0 / 1 0 0 / 1 0 0 - 0 0 0 1

Type

optional - design „B“

optional - brake disc

nominal size of the flange coupling FK

Shaft diameter at flange T1 d<sub>w1</sub>

Shaft diameter at flange T2 d<sub>w2</sub> (not applicable for half FK)

Item number (if known)

Includes reference to:  
 Type of shrink discs  
 Size of shrink discs  
 Toleranced dimensions  
 Tightening torques

## Examples:

TAS FK-090/085/095  
 TAS FKB-090/085/095  
 TAS FKS-090/085/095  
 TAS FKBS-090/085/095

Flange coupling in nominal size FK = 090 / d<sub>w1</sub> = Ø85 / d<sub>w2</sub> = Ø95  
 Flange coupling design „B“ in nominal size FK = 090 / d<sub>w1</sub> = Ø85 / d<sub>w2</sub> = Ø95  
 Flange coupling with brake disc in nominal size FK = 090 / d<sub>w1</sub> = Ø85 / d<sub>w2</sub> = Ø95  
 Flange coupling design „B“ with brake disc in nominal size FK = 090 / d<sub>w1</sub> = Ø85 / d<sub>w2</sub> = Ø95

# Connecting Flange AFS

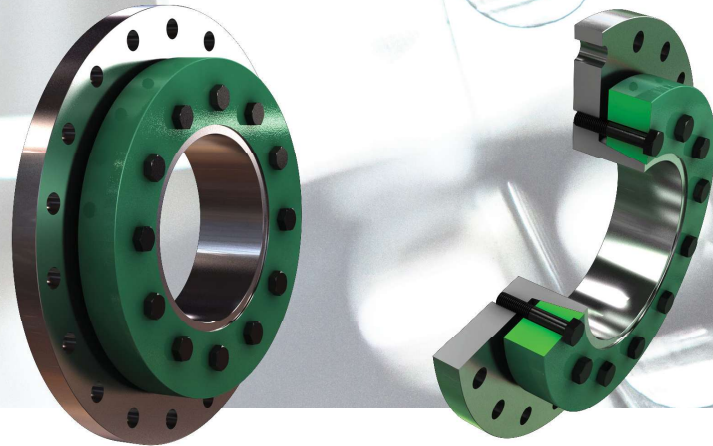
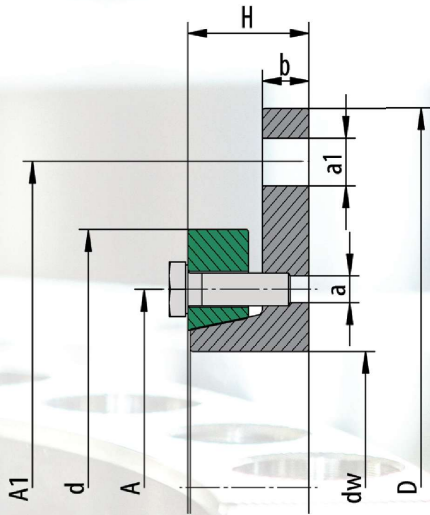

## Used Symbols

$d_w$	[mm]	Shaft diameter
$D$	[mm]	Outer diameter of the connecting flange
$M_{t\max}$	[Nm]	max transmittable torque
$H$	[mm]	Width of the connecting flange
$d$	[mm]	Outer diameter disc D
$A$	[mm]	Pitch circle diameter disc D
$A_1$	[mm]	Pitch circle diameter flange
$b$	[mm]	Width of the flange
$Z$		Number of screws disc D
$S$		Size
$M_A$	[Nm]	Required tightening torque
$S/a$		Number/ Size bores of the flange

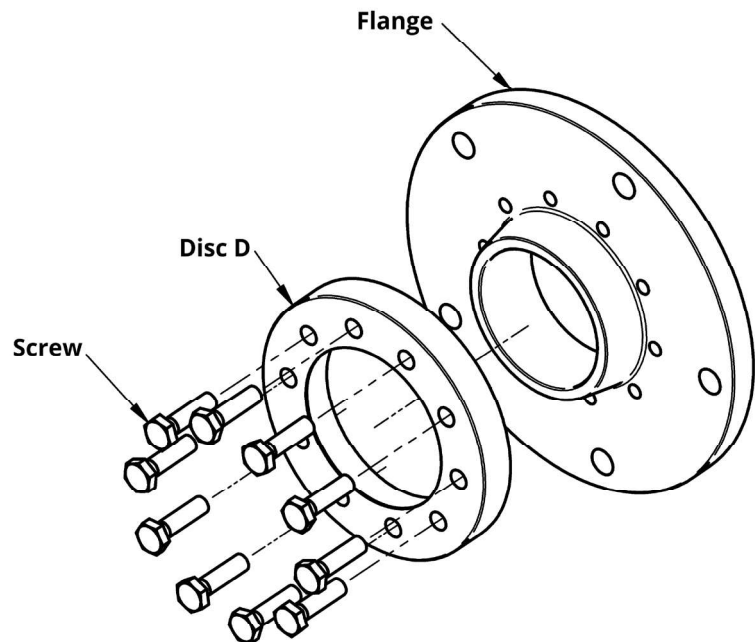

## Design of the connecting flange

Alternative versions with centering, tapped holes and additional sizes on request.

Example: **AFS-200/470**

# Connecting Flange AFS

$d_w$ mm	$D$ mm	$M_{tmax}$ Nm	$H$ mm	$d$ mm	$A$ mm	$Z$ Pcs	$S$	$M_A$ Nm	$A_1$ mm	$S/a$	$M_A$ Nm	$b$ mm	Weight kg
<b>30</b>	<b>105</b>	310	23	70	54	6	M6 x 020	12	90	4/6,6	12	8	1,00
<b>35</b>	<b>110</b>	450	23	75	59	7	M6 x 020	12	95	5/6,6	12	8	1,1
<b>40</b>	<b>130</b>	645	26	85	64	8	M6 x 022	12	110	4/9	30	10	1,3
<b>45</b>	<b>135</b>	850	26	90	68	9	M6 x 022	12	115	4/9	30	10	1,4
<b>50</b>	<b>140</b>	1100	27	95	73	10	M6 x 025	12	120	5/9	30	10	1,7
<b>55</b>	<b>150</b>	1375	27	105	78	11	M6 x 025	12	130	5/9	30	10	1,9
<b>60</b>	<b>155</b>	1725	28	110	84	12	M6 x 025	12	135	6/9	30	10	2,0
<b>65</b>	<b>170</b>	1940	30	125	95	7	M8 x 030	30	150	7/9	30	10	2,6
<b>70</b>	<b>180</b>	2500	30	135	100	8	M8 x 030	30	160	8/9	30	10	3,1
<b>75</b>	<b>195</b>	3000	34	140	105	9	M8 x 030	30	170	6/11	59	12	3,6
<b>80</b>	<b>200</b>	3650	34	145	110	10	M8 x 030	30	175	7/11	59	12	4,1
<b>85</b>	<b>210</b>	4150	37	155	118	11	M8 x 035	30	185	7/11	59	12	4,8
<b>90</b>	<b>215</b>	4950	37	160	123	12	M8 x 035	30	190	8/11	59	12	5,4
<b>100</b>	<b>235</b>	7350	40	180	138	10	M10 x 040	59	210	10/11	59	12	5,7

# AF Series 12

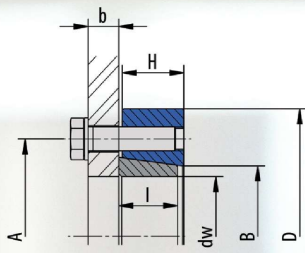

Model A

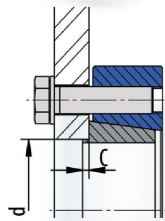

Model AB

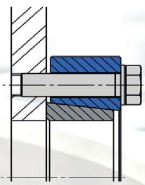

Model C

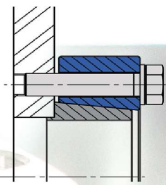

Model BC

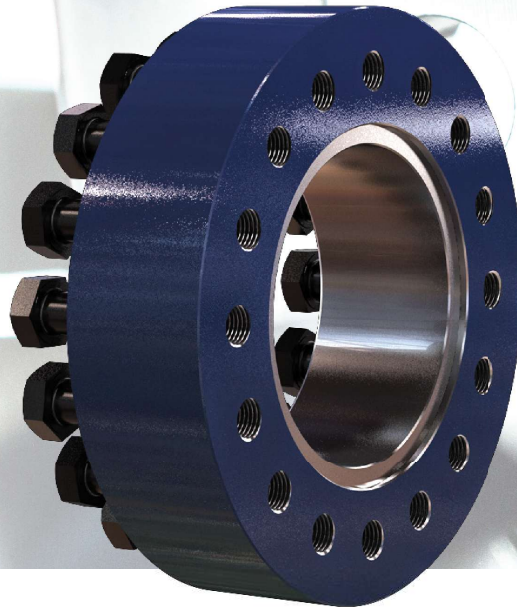

## Used symbols

Typ		Nominal size
$d_w$	[mm]	Shaft diameter
$M_{t\max}$	[Nm]	Max transmittable torque
D	[mm]	Outer diameter
I	[mm]	Length of the bush
H	[mm]	Width of the external clamping element
A	[mm]	Pitch circle diameter
C	[mm]	Length of the centering
d	[mm]	Diameter of the centering
B	[mm]	Attachment size
<b>Screws</b>		
Z		Number of screws
S		Size of screws
$M_A$	[Nm]	Required tightening torque

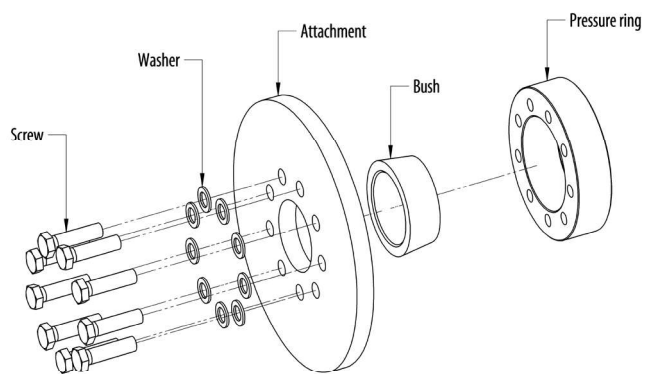

Example: **AF-60-12-60 A**

## Design of the external clamping element

$d < \text{Ø}125$ -pressure rings lightly oiled  
 $d \geq \text{Ø}125$ -pressure rings painted

### Applies to all types:

$b > 1,4 \times \text{Screw diameter}$

From M10 with washers

## Details of the fit

Shaft:

up to  $d_w$  150mm H7 / h6  
 from  $d_w$  155mm H7 / g6

Centring:

up to d 150mm H7 / h6  
 from d 155mm H7 / g6

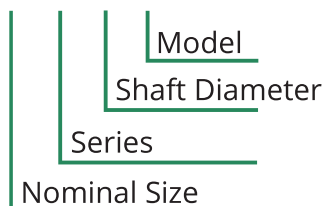

# AF Series 12

Type	$d_w$ mm	$Mt_{max}$ Nm	D mm	I mm	H mm	A mm	C mm	d mm	B mm	Z Pcs.	S	Class	Ma Nm	Weight kg
AF-10	11	20	39	9	10	25	1,5	12	13	3	M6x18	10.9	12	0,1
	10	20												
	9	20												
AF-12	13	50	44	12	13	28	1,5	14	16	3	M6x20	10.9	12	0,1
	12	50												
	11	50												
AF-15	16	130	52	14	15	36	2	18	21	3	M8x25	10.9	29	0,2
	15	130												
	14	130												
AF-20	20	200	60	16	17	42	2	22	25	3	M8x30	10.9	29	0,3
	18	200												
	16	200												
AF-25	25	340	70	18	19	48	2	27	31	5	M8x30	10.9	29	0,4
	22	340												
	20	340												
AF-30	30	550	76	20	21	56	2	32	35	6	M8x35	10.9	29	0,6
	28	550												
	25	550												
AF-40	40	1060	96	24	25	70	3	43	47	6	M10x35	10.9	58	1,2
	35	1060												
	30	1060												
AF-50	50	2200	112	29	30	84	3	53	58	7	M12x45	10.9	100	2
	45	1800												
	40	1000												
AF-60	60	3230	120	32	34	94	3	63	66	9	M12x50	10.9	100	2,3
	55	3230												
	50	2300												
AF-70	70	5800	148	38	40	112	4	74	79	8	M16x60	10.9	240	4,2
	65	5800												
	60	4500												
AF-80	80	8640	170	42	44	130	4	84	94	9	M16x65	10.9	240	6,1
	75	8640												
	70	6900												
AF-90	90	12000	185	48	50	144	4	94	104	12	M16x70	10.9	240	8
	85	12000												
	80	10700												
AF-100	100	15800	197	52	54	156	4	104	113	14	M16x75	10.9	240	9,5
	95	15800												
	90	15800												

# AF Series 22

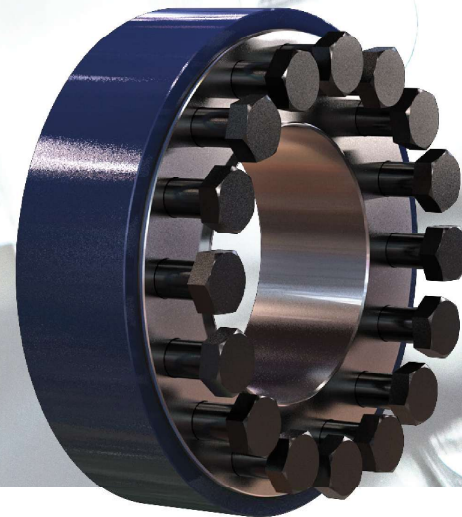
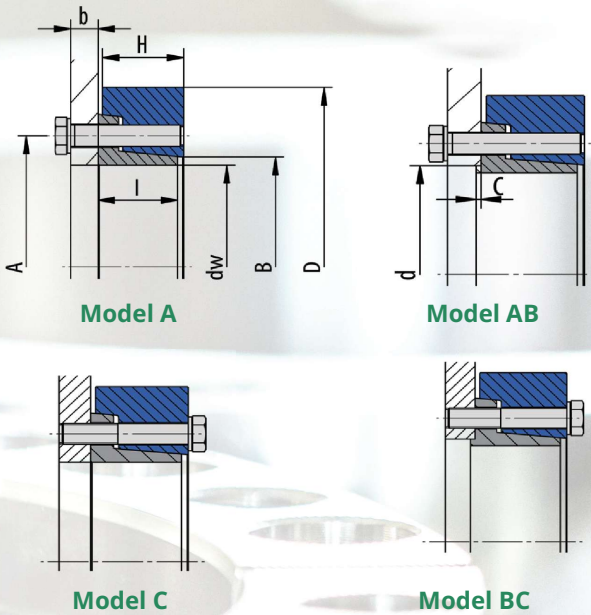

## Used symbols

Typ		Nominal size
$d_w$	[mm]	Shaft diameter
$M_{t\max}$	[Nm]	Max transmittable torque
D	[mm]	Outer diameter
I	[mm]	Length of the bush
H	[mm]	Width of the external clamping element
A	[mm]	Pitch circle diameter
C	[mm]	Length of the centering
d	[mm]	Diameter of the centering
B	[mm]	Attachment size
<b>Screws</b>		
Z		Number of screws
S		Size of screws
$M_A$	[Nm]	Required tightening torque

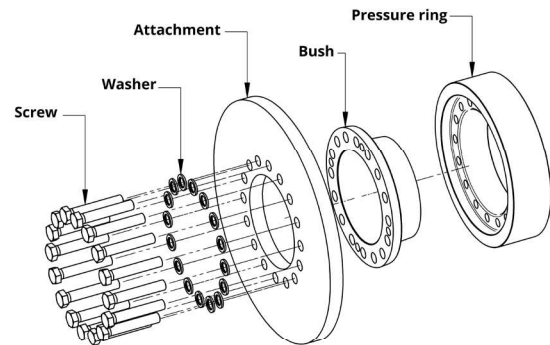

Example: **AF-60-22-60 A**

## Design of the external clamping element

$d < \varnothing 125$ -pressure rings lightly oiled  
 $d \geq \varnothing 125$ -pressure rings painted

### Applies to all types:

$b > 1,4 \times$  Screw diameter

From M10 with washers

## Details of the fit

Shaft:

up to  $d_w$  150mm H7 / h6  
 from  $d_w$  155mm H7 / g6

Centring:

up to d 150mm H7 / h6  
 from d 155mm H7 / g6

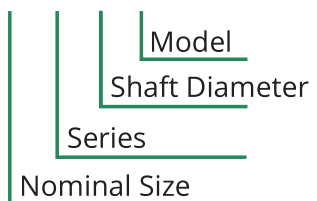

# AF Series 22

Typ	$d_w$ mm	$Mt_{max}$ Nm	D mm	I mm	H mm	A mm	C mm	d mm	B mm	Z Pcs.	S	Class	Ma Nm	Weight kg
AF-12	12	50	35	10	16	24	1,5	14	13	3	M6x20	10.9	12	0,1
	11	50												
AF-14	14	70	38	10	16	26	1,5	16	15	3	M6x20	10.9	12	0,1
	13	70												
AF-16	16	80	41	13,5	20	28	2	18	17	3	M6x25	10.9	12	0,1
	15	80												
AF-18	18	130	44	13,5	20	30	2	20	19	4	M6x25	10.9	12	0,1
	17	130												
AF-20	20	140	47	13,5	20	32	2	22	21	4	M6x25	10.9	12	0,2
	19	140												
AF-25	25	200	50	17	17	36	2	27	26	5	M6x30	10.9	12	0,2
	24	200												
AF-30	22	200	60	18	19	44	3	32	32	6	M6x30	10.9	12	0,3
	30	300												
	28	300												
AF-35	26	300	72	20	21	52	3	38	38	5	M8x35	10.9	29	0,5
	36	500												
	35	500												
AF-40	32	450	80	22	23	61	3	46	47	6	M8x35	10.9	29	0,7
	44	750												
	40	750												
AF-50	38	720	90	24	25	68	3	53	53	8	M8x40	10.9	29	0,9
	50	1300												
	45	1300												
AF-55	42	1000	100	26	27	72	3	58	58	8	M8x40	10.9	29	1,2
	55	1600												
	52	1600												
AF-60	62	2000	110	26	27	80	3	63	66	9	M8x40	10.9	29	1,4
	60	2000												
	50	2000												
AF-70	70	2100	115	26	27	86	4	74	72	9	M8x40	10.9	29	1,5
	65	2100												
	60	2100												
AF-80	80	4000	141	28	29	100	4	84	82	10	M10x45	10.9	58	2,5
	75	4000												
	70	4000												
AF-90	90	5700	155	34	35	114	4	94	94	12	M10x50	10.9	58	3,6
	85	5700												
	80	5700												

# AF Series 22

Type	$d_w$ mm	$Mt_{max}$ Nm	D mm	I mm	H mm	A mm	C mm	d mm	B mm	Z Pcs.	S	Class	Ma Nm	Weight kg
AF-100	100	8400	170	39	40	124	4	104	104	12	M12x60	10.9	100	4,6
	95	8400												
	90	8400												
AF-110	110	9200	185	45	46	136	5	116	114	12	M12x70	10.9	100	6,2
	105	9200												
	100	9200												
AF-125	125	21000	215	48	50	160	5	130	134	12	M16x75	10.9	240	8,8
	120	21000												
	115	21000												
AF-140	140	26000	230	52	54	176	5	146	146	14	M16x80	10.9	240	11
	135	26000												
	130	26000												
AF-155	160	31000	263	54	55	192	5	166	162	15	M16x80	10.9	240	15
	155	31000												
	150	31000												
AF-170	170	36000	290	61	62	204	5	176	175	16	M16x90	10.9	240	21
	165	36000												
	160	36000												
AF-180	180	43000	300	61	62	218	5	186	185	18	M16x90	10.9	240	22
	175	43000												
	170	43000												
AF-190	190	60000	320	77	78	232	5	196	195	15	M20x110	10.9	470	31
	185	60000												
	180	60000												
AF-200	200	67000	340	75	78	246	5	206	209	16	M20x110	10.9	470	35
	195	67000												
	190	67000												
AF-220	220	93000	370	95	96	278	5	226	230	14	M24x130	10.9	820	53
	210	93000												
	200	93000												
AF-240	240	117000	405	98	100	296	5	246	248	16	M24x140	10.9	820	64
	230	117000												
	220	117000												
AF-260	260	126000	430	106	106	318	5	266	266	16	M24x150	10.9	820	80
	250	126000												
	240	126000												
AF-280	280	151000	460	118	118	340	5	286	288	18	M24x160	10.9	820	95
	270	151000												
	260	151000												
AF-300	300	178000	485	125	126	360	5	306	309	20	M24x170	10.9	820	110
	290	178000												
	280	178000												
AF-320	320	248000	520	125	126	380	5	330	328	20	M27x170	10.9	1210	134
	300	248000												
	280	248000												

# AF Series 22

Type	$d_w$ mm	$Mt_{max}$ Nm	D mm	I mm	H mm	A mm	C mm	d mm	B mm	Z Pcs.	S	Class	Ma Nm	Weight kg
AF-340	340	275000	570	134	136	402	5	350	351	21	M27x180	10.9	1210	180
	320	275000												
	300	275000												
AF-360	360	290000	590	142	144	424	8	370	367	21	M27x180	10.9	1210	200
	340	290000												
	320	290000												
AF-390	390	363000	630	146	148	458	8	400	398	20	M30x190	10.9	1640	222
	370	363000												
	350	363000												
AF-420	420	407000	650	166	168	490	8	430	424	21	M30x210	10.9	1640	263
	400	407000												
	380	407000												
AF-440	440	426000	670	174	176	512	8	450	448	21	M30x220	10.9	1640	309
	420	426000												
	400	426000												



# AF Series 23

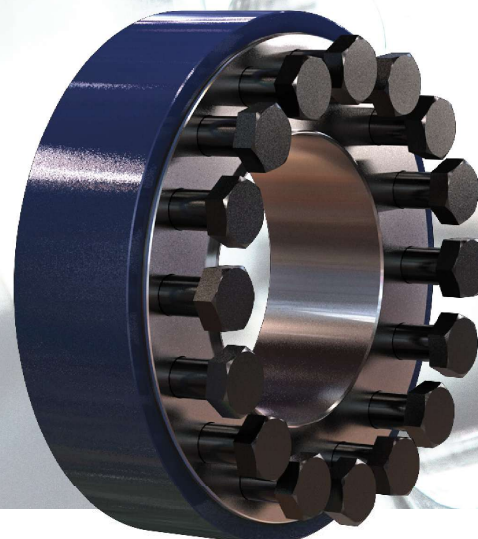
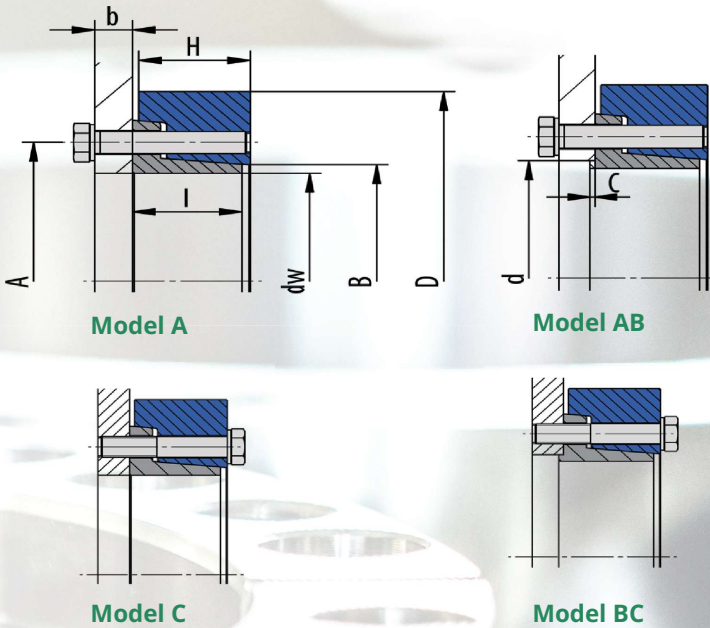

## Used symbols

Typ		Nominal size
$d_w$	[mm]	Shaft diameter
$M_{tmax}$	[Nm]	Max transmittable torque
D	[mm]	Outer diameter
I	[mm]	Length of the bush
H	[mm]	Width of the external clamping element
A	[mm]	Pitch circle diameter
C	[mm]	Length of the centering
d	[mm]	Diameter of the centering
B	[mm]	Attachment size
<b>Screws</b>		
Z		Number of screws
S		Size of screws
$M_A$	[Nm]	Required tightening torque

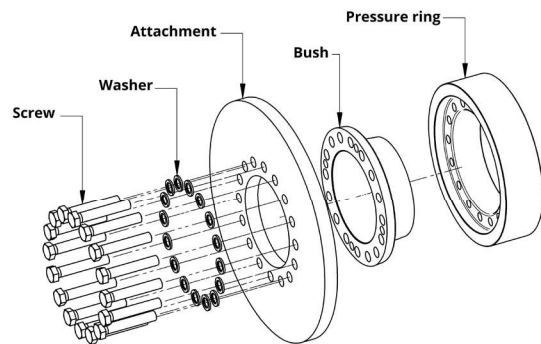

Example: **AF-60-23-60 A**

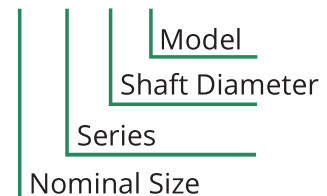

## Design of the external clamping element

$d < \text{Ø}125$ -pressure rings lightly oiled  
 $d \geq \text{Ø}125$ -pressure rings painted

## Applies to all types:

$b > 1,4 \times$  Screw diameter

From M10 with washers

## Details of the fit

Shaft:  
 up to  $d_w$  150mm H7 / h6  
 from  $d_w$  155mm H7 / g6

Centring:  
 up to d 150mm H7 / h6  
 from d 155mm H7 / g6

# AF Series 23

Type	$d_w$ mm	$Mt_{max}$ Nm	D mm	I mm	H mm	A mm	C mm	d mm	B mm	Z Pcs.	S	Class	Ma Nm	Weight kg
AF-50	50	3300	115	29	30	84	3	53	58	7	M12x45	10.9	100	2
	45	2200												
	40	1400												
AF-60	60	4700	120	32	34	94	3	63	66	9	M12x50	10.9	100	2,2
	55	3500												
AF-70	50	2300	148	38	40	112	4	74	79	8	M16x60	10.9	240	3,9
	70	9400												
	65	7600												
AF-80	60	5800	167	43	46	130	4	84	94	9	M16x65	10.9	240	5,4
	80	12000												
	75	10000												
AF-90	70	8000	185	48	50	144	4	94	104	12	M16x70	10.9	240	7,4
	90	18000												
	85	15000												
AF-100	80	12000	197	52	54	156	4	104	114	14	M16x75	10.9	240	8,7
	100	23000												
	95	19000												
AF-110	90	16000	215	56	58	166	5	116	124	10	M20x90	10.9	470	11
	110	27000												
	105	26000												
AF-120	100	22000	230	62	65	186	5	126	134	14	M20x90	10.9	470	13,6
	120	43000												
	115	38000												
AF-140	110	33000	290	75	76	216	5	146	160	16	M20x100	10.9	470	29
	140	56000												
	130	50000												
AF-160	120	39000	320	82	83	234	5	166	180	14	M24x110	10.9	820	36,1
	160	77000												
	150	77000												
AF-180	140	64000	340	91	94	276	5	186	205	16	M24x130	10.9	820	45,3
	180	104000												
	170	101000												
AF-200	160	85000	370	95	96	290	5	206	226	16	M27x140	10.9	1210	53,7
	200	144000												
	190	133000												
AF-220	180	114000	405	96	96	320	5	226	246	18	M27x140	10.9	1210	64,3
	220	178000												
	210	178000												
AF-240	200	159000	430	109	110	340	5	246	267	20	M27x150	10.9	1210	81
	240	211000												
	230	211000												
AF-260	220	178000	460	118	118	356	5	286	289	21	M27x160	10.9	1210	109,4
	260	232000												
	250	234000												
	240	234000												

# AF Series 23

Type	$d_w$ mm	$Mt_{max}$ Nm	D mm	I mm	H mm	A mm	C mm	d mm	B mm	Z Pcs.	S	Class	Ma Nm	Weight kg
AF-280	280	234000	485	124	125	360	5	306	304	21	M27x180	10.9	1210	116
	270	234000												
	260	234000												
AF-300	300	247000	520	128	126	380	5	330	315	21	M27x180	10.9	1210	141
	290	247000												
	280	247000												
AF-320	320	299000	550	134	136	402	5	350	336	24	M27x180	10.9	1210	161
	310	299000												
	300	299000												
AF-340	340	315000	570	140	143	424	8	370	368	24	M27x180	10.9	1210	177
	330	315000												
	320	315000												
AF-360	360	410000	610	144	147	454	8	400	383	24	M30x190	10.9	1640	210
	350	410000												
	340	410000												
AF-390	390	439000	630	164	167	486	8	430	428	24	M30x200	10.9	1640	250
	380	439000												
	360	439000												
AF-420	420	457000	670	172	175	506	10	450	440	24	M30x220	10.9	1640	292
	410	457000												
	390	457000												
AF-440	440	562000	700	172	175	534	10	470	468	28	M30x220	10.9	1640	318
	420	562000												
	400	562000												



**Modern  
mechanical  
processing  
in perfection**

**TAS**  
**SCHÄFER**