

**TAS**  
**SCHÄFER**



# Flange Coupling

Connecting flange, rigid connection



# Description of function FK

## Rigid flange coupling with three-parted shrink disc of the type TAS 30..

The main function of the rigid flange coupling (FK) is the safe and backlash-free connection of two shafts by means of friction. For example, between a drive shaft and an agitator shaft. Flange couplings are directly separable at the flanges. The used shrink discs generate a backlash-free connection by pressing the flange-hubs onto the shafts. This connection is mainly used to transmit torque.

The shrink discs do not transmit any forces and/or moments between the shafts and hubs, they just provide the necessary forces. They are not in the flow of forces.

It is installed by sliding the flanges onto the shaft ends and subsequent tightening of the shrink disc. Thereafter the flanges are connected by bolting.

The rigid flange couplings are supplied ready for installation.

To achieve proper operation and a sufficiently high coefficient of friction, the contact surfaces between the shaft extensions and flange-hubs, as well as the contact surfaces of the flanges, must be free of grease, dry and clean. The functional surfaces of the shrink disc, threads and head rests of the screws are provided at the factory with lubricant. The contact surfaces between the flange-hubs and shrink discs are oiled.

A detailed installation manual is available on the Internet.

### Product data

#### Data sheets

- Contact us if a data sheet for an individual product is required.

For CAD data of flange couplings, contact us directly, please.

**Rolf Gertner**  
rolf.gertner@tas-schaefer.de

or

**Mike Kemper**  
mike.kemper@tas-schaefer.de

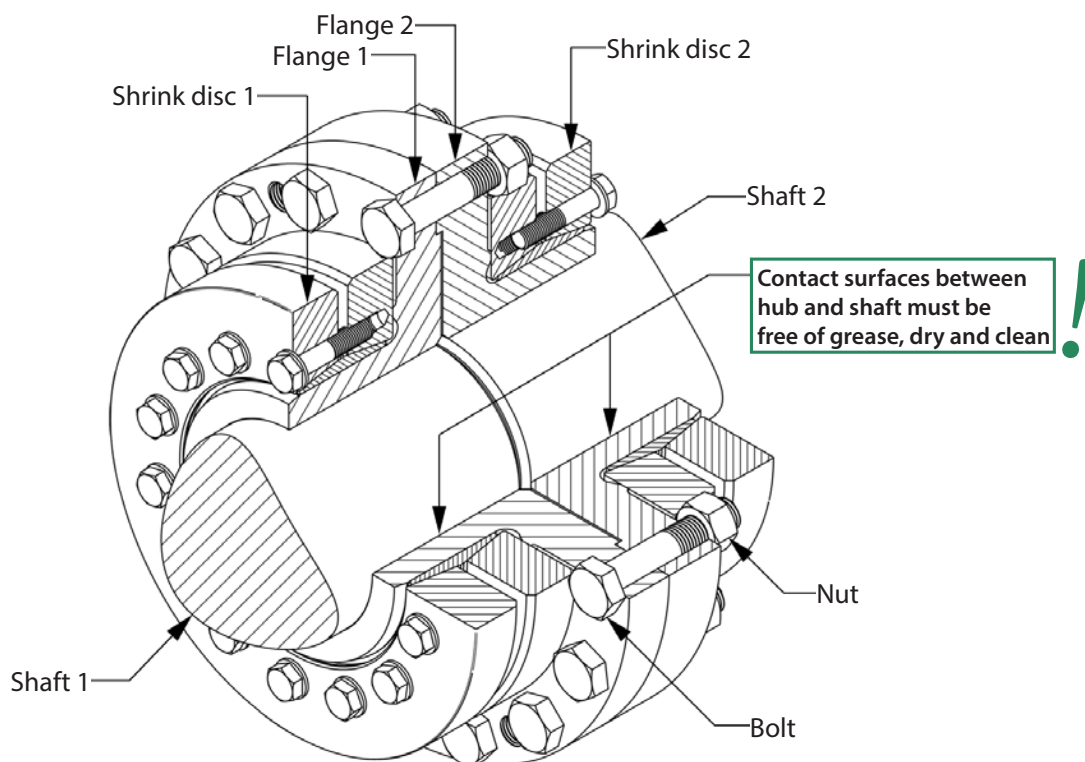

# Basics - Calculation FK

## Advantages and differences to other systems

- **Use of shrink discs / flow of forces**

Due to the use of shrink discs, the forces and moments are transferred directly between the shaft and flange. In comparison with internal clamping systems the achievable runout accuracy is higher.

- **Pursue the same diameter - but an adaptation to different diameters is also possible**

Basically the target should be to connect shaft ends of the same size. With larger deviations the flange-hubs can be adapted for the different diameters. This is done by using different shrink discs.

- **Tightening torque of the clamping screws**

When using different shrink discs and shaft diameters, the tightening torque and therefore the clamping forces of the shrink discs are adjustable. For example, this is also possible with soft shaft materials and reduces, if required, the stresses in the components.

- **Positioning**

The cylindrical connection, as well as the used clearance, allows an easy and precise positioning of the flanges on the shaft ends. During the clamping process there is no more shift.

- **Short length (B version)**

The design „B“, with clamping the shrink discs through the flange face, provides a very short mounting length, as there is no extra space needed behind the coupling.

- **No hydraulic necessary**

A hydraulic expansion of the hubs is not necessary for mounting.

- **No heating necessary**

There is no need for expansion of the hubs by heating. To increase the clearance between the shaft and flange, a slight warming is possible.

- **Shafts with keyways**

The couplings can be used on shafts with keyways. As far as possible, the keyways should be closed.

- **Tolerances and surfaces**

The values found in the product data, are based on surface quality and tolerances, according to the table below. These values are given as recommendations.

Higher values for the surface roughness reduce the transmissible torque and promote unwanted settling.

Larger clearance also reduces the transmissible torque and increases stresses in the flange-hub.

**If you have different shaft tolerances, please let us know. Then we can adjust the bores in the flanges accordingly!**

Recommended tolerances and surface roughness				
>	≤	FS <sub>max</sub> mm	Clearance Hub / Shaft	Rz µm
9	18	0,022	H6/h6	10
18	30	0,026	H6/h6	10
30	50	0,032	H6/h6	10
50	80	0,049	H7/h6	10
80	120	0,057	H7/h6	16
120	150	0,065	H7/h6	16
150	180	0,079	H7/g6	16
180	250	0,090	H7/g6	16
250	315	0,101	H7/g6	16
315	400	0,111	H7/g6	16
400	500	0,123	H7/g6	25
500	630	0,136	H7/g6	25
630	800	0,154	H7/g6	25
800	1000	0,172	H7/g6	25

# Basics - Calculation FK

The calculation of the values, given in the catalogue, are based on the following assumptions and simplifications:

## Distinction flange connection / shrink disc

Due to the design, the transmissible forces and torque, are to look separately for the shrink disc and the flange. While the shrink disc provides clamping forces only, the transmissible forces and torque must be accommodated by the flange. This results in different values for shrink connection and flange.

## Transmissible torque at the shrink disc

A shrink disc connection is capable of transmitting torque, bending moment and axial force. Substituted, the transmissible torque  $M_{max}$  is specified in the product data. If such loads occur simultaneously then they must be added vectorially to the resultant moment  $M_{res}$ . The formula below applies to the resulting moment:

$$M_{res} \leq M_{max}$$

At different load cases, they must be individually checked against  $M_{max}$  !

$M_{res}$  is determined for combined loads as follows:

$$M_{res} = \sqrt{M_T^2 + 2M_B^2 + (F_{AX} \frac{d_W}{2})^2}$$

with  $M_B \leq 0,3 M_{max}$   
as the limit \* for the bending moment

\*In principle, the maximum bending moment corresponds to the maximum transmittable torque. The limitation to  $0,3 M_{max}$  is due to the change of the surface pressure at the edges of the connection.  
(This information applies to the shrink connection only!)

## This results in the following relationships:

### Nur Drehmoment:

The maximum torque is equivalent to  $M_{max}$ .

### Nur Biegemoment:

The maximum static bending moment corresponds to  $0,4 M_{max}$ .

## Axial force only :

The maximum axial force is  $M_{max} \frac{2}{d_W}$

In addition, the load on the flange bolting connection must be taken into account

Transmissible forces and torque at the flange connection

The bolt connection of the flanges is also based on friction. The torque is transmitted via this connection. Whereas the torque capacity usually corresponds to, or is higher than that of the shrink connection it is any transmissible bending moment which must be particularly considered.

Bending influences the bolt connections and the flange itself. The static load case usually corresponds to the transmissible bending moment of the shrink connection, the bending moment capacity is however lower in the dynamic load and will be determined for each individual case by us (refer to the Product questionnaire).

The same applies to axial loads, as they are transmitted directly by the bolt connection of the flanges.

## Static and dynamic load

For some applications, a static review of the coupling is sufficient. The clamping forces of the shrink connection are static. Non cyclic torques and/or axial forces can also be considered as static loads. Rotating bending has to be considered as a dynamic load and the coupling must be calculated accordingly. Therefore it is also essential to specify the actual occurring load cases.

## Shaft and hub calculation

The flange-hub will be deformed due to the applied clamping force. Shaft stiffness and surface finish should be considered in addition to the clearance between shaft and hub. Stiffness can be ignored for solid shafts, but for hollow shafts (see „Bore in the shaft (hollow shaft)“) there is higher deformation and thus higher stresses in the components. This must be considered in addition to other loads.

The stresses in the hub can be determined by various hypotheses, such as GEH. A discussion and analysis of results is not made here because only a very limited range of static applications could be covered. Various calculation methods for different cases can be found in engineering literature or using specialised software. Often only a calculation via FEA will give reliable results for complex geometry

## Notch effect

Generally there is a notch effect on the components caused by the radial pressure of the pressure ring. This depends mainly on the applied pressure. The notch effect is generally higher on the hub than on the shaft, because the pressure ring is directly pressed onto the hub, while the stresses are distributed through the hub before reaching the shaft. The notch factors range from 2,5 to 3,5 for the hub and between 1,5 and 2 for the shaft. This can be mitigated by suitable design features, such as relief notches.

Some standards provide the possibility for a notch factor to be determined by a fit pairing (interference fit) for a shrink-connection. A similar method can also be used for such shrink connections. To this end an oversize can be calculated from the applied surface pressures. As a result a matching fit pair can be determined and thus a resultant notch factor found.

## Bore in the shaft (hollow shaft)

A large bore  $d_B$  in the shaft or the use of a hollow shaft, reduces the stiffness of the shaft against radial pressure. This leads to a decrease in pressure  $p_W$ , a reduced transmissible torque  $M$ , a contraction  $\Delta d_B$  within the shaft and an increase of stresses in these components. Basically, a bore should not be greater than  $0,3 d_W$ .

# Rigid Flange Coupling FK/FKB

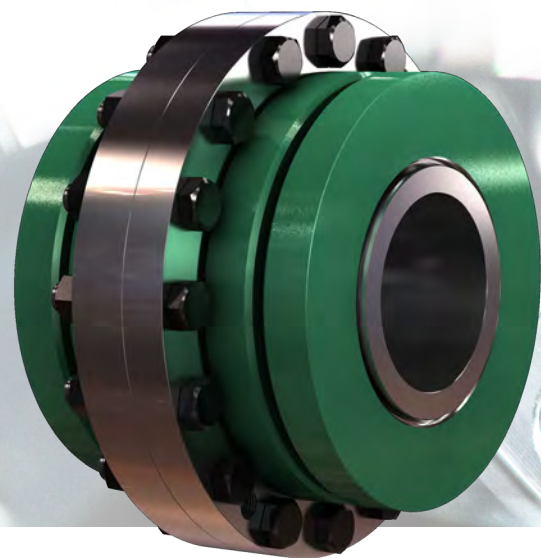
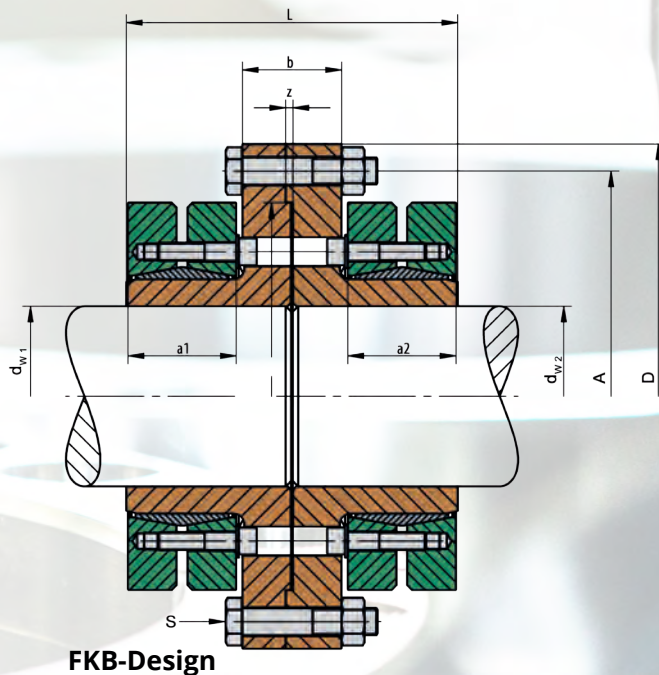

## Used symbols

<i>FK</i>		Nominal size
$d_{w1}$ & $d_{w2}$ [mm]		Shaft diameters
$M_{tmax}$ [Nm]		Maximal transmittable torque (depends on used shrink disc and $d_w$ )
<i>A</i> [mm]		Pitch circle diameter
<i>D</i> [mm]		Outer diameter
$D_z$ [mm]		Diameter of the flange centering
<i>L</i> [mm]		Width of the flange coupling
<i>a</i> [mm]		Width of the shrink disc
<i>b</i> [mm]		Thickness of flange
<i>z</i> [mm]		Depth of the centering
<i>I</i> [kgm <sup>2</sup> ]		Moment of inertia
<b>Bolts</b>		
<i>Z</i>		Number
<i>S</i>		Size
$M_A$ [Nm]		Required tightening torque

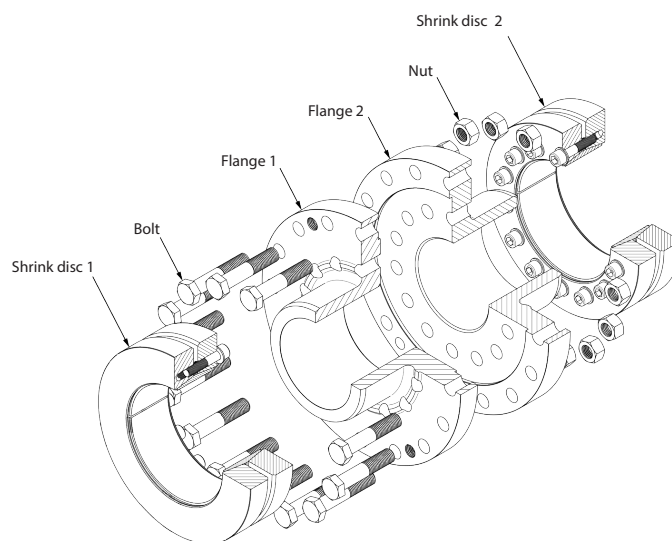

# Rigid Flange Coupling FK/FKB

FK	d <sub>w</sub> mm	M <sub>t max</sub> Nm	Shrink disc		Dimensions							Flange bolts			I kgm <sup>2</sup>	Weight kg
			Type 3071-d	M <sub>A</sub> Nm	A mm	D mm	D <sub>z</sub> mm	L mm	a mm	b mm	z mm	Z Stk	S	M <sub>A</sub> Nm		
75	75	7300	100	30	210	240	170	136	44	44	4	6	M 16 x 70	210	0,165499	26
90	90	13100	125	59	265	305	215	160	54	48	5	6	M 20 x 80	420	0,487699	48
100	100	17900	140	100	286	340	230	190	64	56	5	5	M 24 x 90	720	0,829143	63
120	120	38700	165	250	356	400	300	228	75	72	5	8	M 24 x 110	720	2,126131	120
130	130	42600	175	250	356	400	300	228	75	72	5	8	M 24 x 110	720	2,246611	120
150	150	79500	195	250	420	475	350	278	90	90	6	10	M 30 x 130	1450	5,408399	215
165	165	103000	220	250	440	510	370	314	108	90	6	14	M 30 x 130	1450	7,692146	270
180	180	144000	240	490	475	540	405	322	113	88	6	16	M 30 x 130	1450	10,247074	310
200	200	193000	<sup>(1)</sup> 260	490	500	560	430	368	125	110	8	16	M 30 x 150	1450	14,889123	395
220	220	251000	280	490	530	590	460	392	139	104	8	18	M 30 x 150	1450	18,392262	445
240	240	318000	300	490	555	615	485	408	147	104	8	20	M 30 x 150	1450	22,627586	500
260	260	435000	340	490	640	710	570	450	161	118	8	24	M 30 x 160	1450	45,880687	780
290	290	519000	360	490	660	720	590	450	167	106	8	24	M 30 x 150	1450	76,117692	790
310	310	697000	390	840	735	805	660	484	180	114	8	28	M 30 x 160	1450	81,558246	1060
340	340	891000	420	840	770	835	690	530	198	122	10	30	M 30 x 160	1450	102,442438	1230
380	380	1198000	460	840	845	920	770	556	208	128	10	35	M 30 x 170	1450	166,038502	1420
410	410	1431000	500	1250	940	1030	850	618	225	156	12	32	M 36 x 200	2400	283,051874	2200
440	440	1961000	530	1250	1000	1100	900	696	258	160	14	36	M 36 x 200	2400	382,170457	2680
470	470	2397000	590	1250	1080	1180	980	744	280	164	14	40	M 36 x 200	2400	553,092493	3340
500	500	2742000	620	1250	1110	1210	1020	744	280	164	14	42	M 36 x 200	2400	638,288490	3620

<sup>(1)</sup> 3071.4

## How to order (product identification)

T A S F K B S - 0 9 0 / 1 0 0 / 1 0 0 - 0 0 0 1

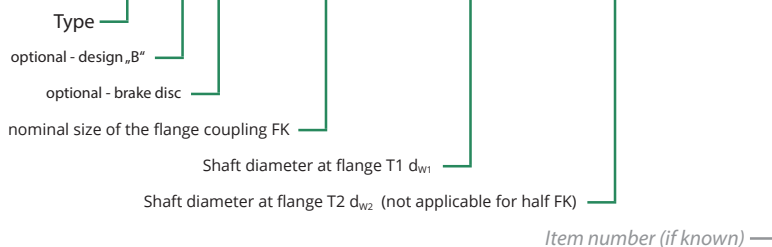

Includes reference to:  
Type of shrink discs  
Size of shrink discs  
Toleranced dimensions  
Tightening torques

## Examples:

TAS FK-090/085/095

Flange coupling in nominal size FK = 090 / d<sub>w1</sub> = Ø85 / d<sub>w2</sub> = Ø95

TAS FKB-090/085/095

Flange coupling design „B“ in nominal size FK = 090 / d<sub>w1</sub> = Ø85 / d<sub>w2</sub> = Ø95

TAS FKS-090/085/095

Flange coupling with brake disc in nominal size FK = 090 / d<sub>w1</sub> = Ø85 / d<sub>w2</sub> = Ø95

TAS FKBS-090/085/095

Flange coupling design „B“ with brake disc in nominal size FK = 090 / d<sub>w1</sub> = Ø85 / d<sub>w2</sub> = Ø95



# Description of function FKE

## Rigid flange coupling with pressure ring

The main function of the rigid flange coupling (FKE) is the safe and backlash-free connection of two shafts by means of friction. For example, between a drive shaft and an agitator shaft. Flange couplings are directly separable at the flanges. The pressure ring generates a backlash-free connection by pressing the flange-hub onto the shaft. This connection is mainly used to transmit torque. It can also transmit axial forces and bending moments.

The shrink connection itself does not transmit any forces and/or moments between the shaft and hub, it just provides the necessary forces between the two. The shrink connection is not part of the flow of forces.

Installation is by sliding the flanges onto the shaft ends and subsequently tightening of the pressure ring. Thereafter the flanges are connected by a second series of bolts.

The rigid flange couplings are supplied ready for installation. The clamping is achieved manually by means of a torque wrench. Optionally a hydraulic clamping tool can be used.

To achieve proper operation and a sufficiently high coefficient of friction, the contact surfaces between the shaft extension and flange-hub, as well as the contact surfaces of the flange, must be free of grease, dry and clean. The functional surfaces of the cones, threads and head seats of the

bolts are supplied at the factory lubricated.

A detailed installation manual is available on the Internet. ([www.tas-schaefer.de](http://www.tas-schaefer.de))

### Product data

#### Data sheets

- Contact us if a data sheet for an individual product is required.

Contact us for CAD data of flange couplings. These are provided upon request.

**Rolf Gertner**  
rolf.gertner@tas-schaefer.de

or

**Mike Kemper**  
mike.kemper@tas-schaefer.de

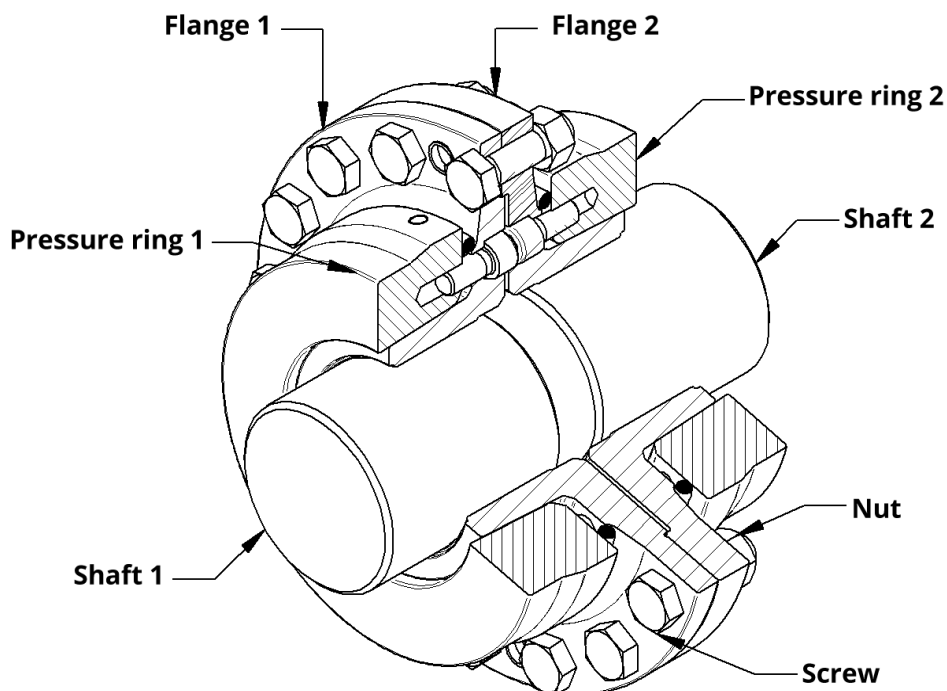

# Basics - Design FKE

## Advantages and differences compared to other systems

- **Use of pressure rings / flow of forces**

Forces and moments are transferred directly between the shaft and flange due to the use of the pressure ring. The achievable runout accuracy is higher compared to internal clamping systems.

Similar shaft diameters preferred - but an adaptation to different diameters is also possible

Basically, the goal should be to connect shaft ends of the similar size. Flange hubs can however be adapted to larger shaft diameter differences. This is done by using different pressure rings and adapting the flanges.

- **Tightening torque of the clamping screws**

The tightening torque and therefore the clamping forces can be adjusted when using different pressure rings and shaft diameters. As an example, it is also possible to use soft shaft materials reducing the stresses in the components.

- **Positioning**

The cylindrical shaft connection and the clearance fit allow for an easy and precise positioning of the flanges on the shaft ends. During the clamping process there is no shifting of the shaft.

- **Short length**

The clamping of the pressure ring through the flange face provides a design with a very short mounting length, as no extra space is needed behind the coupling.

- **No hydraulic necessary**

Hydraulic expansion of the hubs is not necessary for mounting.

- **No heating necessary**

There is no need for expansion of the hubs by heating. A slight warming of the hub is possible to increase the clearance between the shaft and flange.

- **Shafts with keyways**

The couplings can be used on shafts with keyways. As far as possible, the keyways should be closed.

- **Tolerances and surfaces**

The values found in the product datasheet, are based on specific surface qualities and tolerances according to the table below. These values are given as recommendations.

Higher surface roughness reduces the transmissible torque and can lead to unwanted settling.

Larger clearance also reduces the transmissible torque and increases stresses in the flange-hub.

Please advise if different shaft tolerances are required. The bore tolerances can then be adjusted accordingly!

Recommended tolerances and surface roughness

>	≤	FS <sub>max</sub> mm	Clearance Hub / Shaft	Rz µm
9	18	0,022	H6/h6	10
18	30	0,026	H6/h6	10
30	50	0,032	H6/h6	10
50	80	0,049	H7/h6	10
80	120	0,057	H7/h6	16
120	150	0,065	H7/h6	16
150	180	0,079	H7/g6	16
180	250	0,090	H7/g6	16
250	315	0,101	H7/g6	16
315	400	0,111	H7/g6	16
400	500	0,123	H7/g6	25
500	630	0,136	H7/g6	25
630	800	0,154	H7/g6	25
800	1000	0,172	H7/g6	25



# Basics - Calculation FKE

The calculation of the values, given in the catalogue, are based on the following assumptions and simplifications:

## Distinction between flange connection & pressure ring

The transmissible forces and torque are considered separately for the pressure ring and the flange due to the coupling design. While the pressure ring provides clamping forces only, the transmissible forces and torque must be accommodated by the flange. This results in different values for the shrink connection and the flange.

## Transmissible torque

A shrink connection is capable of transmitting torque, bending moment and axial force. The transmissible torque  $M_{\max}$  is specified in the product data as a sole parameter. If additional loads occur simultaneously then they must be added vectorially to the resultant moment  $M_{\text{res}}$ . The formula below applies to the resulting moment:

$$M_{\text{res}} \leq M_{\max}$$

Each different load case must be individually checked against  $M_{\max}$  !

$M_{\text{res}}$  is determined for combined loads as follows:

$$M_{\text{res}} = \sqrt{M_T^2 + 2M_B^2 + (F_{\text{AX}} \frac{d_W}{2})^2}$$

with  $M_B \leq 0,4 M_{\max}$   
as the limit\* for the  
static bending moment

\*In principle, the maximum bending moment corresponds to the maximum transmissible torque. The limitation of  $0,4 M_{\max}$  is due to the change of the surface pressure at the edges of the connection. (This information applies to the shrink connection of the coupling only!)

## This results in the following relationships:

### Torque only:

The maximum torque is equivalent to  $M_{\max}$  .

### Bending moment only:

The maximum static bending moment corresponds to  $0,4 M_{\max}$  .

### Axial force only:

The maximum axial force is

$$M_{\max} \frac{2}{d_W} .$$

In addition, the load on the flange bolting connection must be taken into account

## Transmissible forces and torque at the flange connection

The bolt connection of the flanges is also based on friction. The torque is transmitted via this connection. Whereas the torque capacity usually corresponds to, or is higher than that of the shrink connection it is any transmissible bending moment which must be particularly considered.

Bending influences the bolt connections and the flange itself. The static load case usually corresponds to the transmissible bending moment of the shrink connection, the bending moment capacity is however lower in the dynamic load and will be determined for each individual case by us (refer to the Product questionnaire).

The same applies to axial loads, as they are transmitted directly by the bolt connection of the flanges.

## Static and dynamic load

For some applications, a static review of the coupling is sufficient. The clamping forces of the shrink connection are static. Non cyclic torques and/or axial forces can also be considered as static loads. Rotating bending has to be considered as a dynamic load and the coupling must be calculated accordingly. Therefore it is also essential to specify the actual occurring load cases.

## Shaft and hub calculation

The flange-hub will be deformed due to the applied clamping force. Shaft stiffness and surface finish should be considered in addition to the clearance between shaft and hub. Stiffness can be ignored for solid shafts, but for hollow shafts (see „Bore in the shaft (hollow shaft)“) there is higher deformation and thus higher stresses in the components. This must be considered in addition to other loads.

The stresses in the hub can be determined by various hypotheses, such as GEH. A discussion and analysis of results is not made here because only a very limited range of static applications could be covered. Various calculation methods for different cases can be found in engineering literature or using specialised software. Often only a calculation via FEA will give reliable results for complex geometry

## Notch effect

Generally there is a notch effect on the components caused by the radial pressure of the pressure ring. This depends mainly on the applied pressure. The notch effect is generally higher on the hub than on the shaft, because the pressure ring is directly pressed onto the hub, while the stresses are distributed through the hub before reaching the shaft. The notch factors range from 2,5 to 3,5 for the hub and between 1,5 and 2 for the shaft. This can be mitigated by suitable design features, such as relief notches.

Some standards provide the possibility for a notch factor to be determined by a fit pairing (interference fit) for a shrink-connection. A similar method can also be used for such shrink connections. To this end an oversize can be calculated from the applied surface pressures. As a result a matching fit pair can be determined and thus a resultant notch factor found.

## Bore in the shaft (hollow shaft)

A large bore  $d_B$  in the shaft or the use of a hollow shaft, reduces the stiffness of the shaft against radial pressure. This leads to a decrease in pressure  $p_W$ , a reduced transmissible torque  $M$ , a contraction  $\Delta d_B$  within the shaft and an increase of stresses in these components. Basically, a bore should not be greater than  $0,3 d_W$  .

# Rigid Flange Coupling FKE

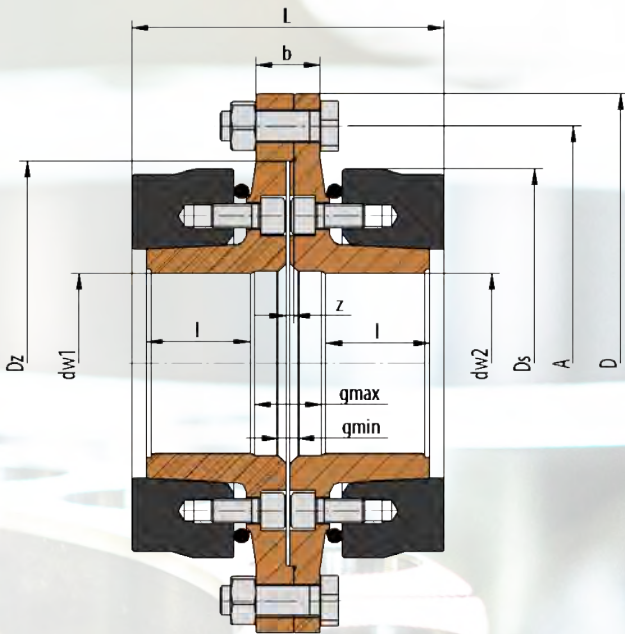

## Used symbols

FKE		Nominal size
$d_w$	[mm]	Shaft diameters
$Mt_{max}$	[Nm]	Maximum transmittable torque
$Mbs_{max}$	[Nm]	Maximum transferable bending moment (static)
$Mbd_{max}$	[Nm]	Maximum transferable bending moment (dynamic)
$D_s$	[mm]	Outer diameter of pressure ring
Z	[Stk.]	Number of clamping screws
S		Screw size of clamping screws
$M_A$	[Nm]	Required tightening torque for clamping screws
A	[mm]	Pitch circle diameter of connecting screws
D	[mm]	Outer diameter of the flange coupling
$D_z$	[mm]	Diameter of the flange recess
L	[mm]	Width of the flange coupling
l	[mm]	Clamping length
$g_{min}$	[mm]	Minimum shaft distance
$g_{max}$	[mm]	Maximum shaft distance
b	[mm]	Thickness of flanges
z	[mm]	Depth of the recess
$Z_F$	[Stk.]	Number of connecting screws
$S_F$		Screw size of connecting screws
$M_{AF}$	[Nm]	Required tightening torque of connecting screws
$n_{max}$	[min <sup>-1</sup> ]	Allowed rotation frequency
I	[kgm <sup>2</sup> ]	Moment of inertia
m	[kg]	Mass of the complete coupling
ph	[bar]	Hydraulic pressure for opt. Clamping tool

Pos.	Designation
1	Flange
2	Pressure ring
3	Clampingscrews
4	Seal
5	Plug
6	Plug
7	O-Ring
8	Connectingscrews
9	Nut

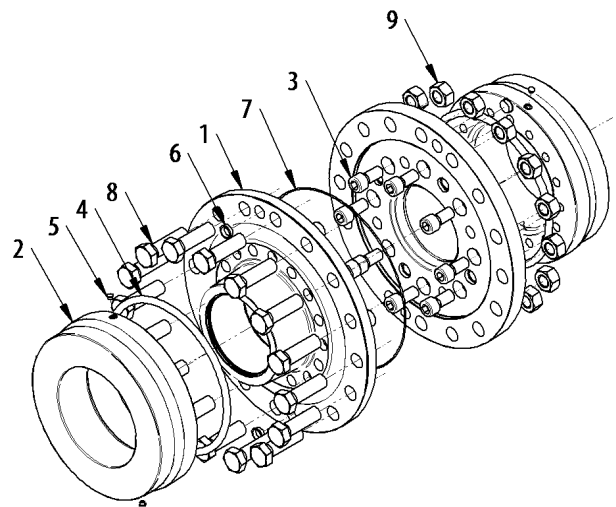

Size FKE (mm)	Shaft d <sub>W</sub> (mm)	Moment		Bend stat.		Bend dyn.		Pressure Ring			Details Coupling							Flange Screws				Further Details			Clampingtool	
		M <sub>max</sub> (Nm)	MBS (Nm)	MBS (Nm)	M <sub>dyn</sub> (Nm)	D <sub>s</sub> (mm)	Z (Stk.)	S	M <sub>t</sub> (Nm)	A (mm)	D (mm)	Dz (mm)	L (mm)	l (mm)	g <sub>min</sub> (mm)	g <sub>max</sub> (mm)	b (mm)	z (mm)	Z <sub>s</sub> (Stk.)	S <sub>t</sub>	M <sub>st</sub> (Nm)	n <sub>max</sub> (min <sup>-1</sup> )	j <sup>st</sup> (kgm <sup>-2</sup> )	m <sup>st</sup> (kg)	ph (bar)	
<b>50</b>	40	1030	412	309	118	6	M8x25	22	170	200	125	111	35	1	27	29	4	6	M12x45	85	3237	0,047	11,5	-		
	50	2100	840	630	134	8	M8x30	21	190	220	145	123	37	1	33	34	4	6	M16x55	210	2851	0,085	16	-		
<b>60</b>	50	1900	760	570	158	8	M10x30	40	210	240	170	147	46	1	37	34	4	6	M16x55	210	2418	0,14	22,5	-		
	60	3200	1280	690	200	8	M12x40	75	265	305	215	174	56	2	42	42	5	6	M20x70	420	1910	0,44	44,5	-		
<b>75</b>	65	4800	1920	1440	214	9	M12x40	80	286	340	230	188	60	2	46	44	5	5	M24x80	720	1785	0,67	56	-		
	75	7300	2920	2190	276	8	M16x50	200	356	400	300	220	71	2	52	54	5	8	M24x90	720	1384	1,7	105	-		
<b>90</b>	80	9800	3920	2490	284	8	M16x50	200	356	400	300	220	71	2	52	54	5	8	M24x90	720	1345	1,75	105	-		
	90	13100	5240	3930	320	8	M20x50	400	420	475	350	264	84	2	66	64	6	10	M30x100	1450	1194	4,2	175	235		
<b>100</b>	90	13500	5400	4050	345	8	M24x50	530	440	510	370	296	100	2	66	64	6	14	M30x100	1450	1107	5,6	205	230		
	100	17900	7160	5370	390	8	M24x50	690	475	540	405	312	108	2	66	64	6	16	M30x100	1450	979	8	260	240		
<b>120</b>	100	24700	9880	7410	415	8	M27x60	800	500	560	430	350	123	2	70	72	8	16	M30x110	1450	920	10,7	315	245		
	120	38700	15480	11610	445	8	M27x60	860	530	590	460	372	135	2	70	72	8	18	M30x110	1450	858	14	370	240		
<b>130</b>	110	28700	11480	8610	467	9	M27x60	870	555	615	485	394	145	2	74	72	8	20	M30x110	1550	818	17,5	420	235		
	130	42600	17040	12780	548	9	M33x65	1720	640	710	570	434	153	2	92	86	8	24	M30x130	1550	697	36,5	660	240		
<b>150</b>	130	57500	23000	17250	560	9	M33x65	1720	660	720	590	444	158	2	92	86	8	24	M30x130	1550	682	39	660	225		
	150	80000	32000	24000	615	9	M36x80	2300	735	805	660	482	170	2	102	92	8	28	M30x130	1550	621	63,5	890	240		
<b>165</b>	135	64000	25600	19200	615	9	M36x80	2300	735	805	660	482	170	2	102	92	8	28	M30x130	1550	621	63,5	890	240		
	165	103000	41200	30900	690	8	M24x50	530	440	510	370	296	100	2	66	64	6	14	M30x100	1450	1107	5,6	205	230		
<b>180</b>	150	93000	37200	27900	390	8	M24x50	690	475	540	405	312	108	2	66	64	6	16	M30x100	1450	979	8	260	240		
	180	144000	57600	43200	415	8	M27x60	800	500	560	430	350	123	2	70	72	8	16	M30x110	1450	920	10,7	315	245		
<b>200</b>	170	129000	51600	38700	415	8	M27x60	800	500	560	430	350	123	2	70	72	8	16	M30x110	1450	920	10,7	315	245		
	200	190000	76000	57000	445	8	M27x60	860	530	590	460	372	135	2	70	72	8	18	M30x110	1450	858	14	370	240		
<b>220</b>	180	156000	62400	46800	445	8	M27x60	860	530	590	460	372	135	2	70	72	8	18	M30x110	1450	858	14	370	240		
	220	250000	100000	75000	467	9	M27x60	870	555	615	485	394	145	2	74	72	8	20	M30x110	1550	818	17,5	420	235		
<b>240</b>	200	205000	82000	61500	467	9	M27x60	870	555	615	485	394	145	2	74	72	8	20	M30x110	1550	818	17,5	420	235		
	240	315000	126000	90000	548	9	M33x65	1720	640	710	570	434	153	2	92	86	8	24	M30x130	1550	697	36,5	660	240		
<b>260</b>	220	297000	118800	71400	548	9	M33x65	1720	640	710	570	434	153	2	92	86	8	24	M30x130	1550	697	36,5	660	240		
	260	435000	174000	130500	560	9	M33x65	1720	660	720	590	444	158	2	92	86	8	24	M30x130	1550	682	39	660	225		
<b>290</b>	240	336000	134400	100800	560	9	M33x65	1720	660	720	590	444	158	2	92	86	8	24	M30x130	1550	682	39	660	225		
	290	519000	207600	155700	615	9	M36x80	2300	735	805	660	482	170	2	102	92	8	28	M30x130	1550	621	63,5	890	240		
<b>310</b>	260	462000	184800	138600	615	9	M36x80	2300	735	805	660	482	170	2	102	92	8	28	M30x130	1550	621	63,5	890	240		
	310	697000	278800	178000																						



Size FKE (mm)	Shaft d <sub>W</sub> (mm)	Moment M <sub>T</sub> (Nm)	Bend stat. M <sub>BS</sub> (Nm)	Bend dyn. M <sub>BD</sub> (Nm)	Pressure ring			Details Coupling							Flange Screws			Further Details			Clamping tool ph (bar)				
					D <sub>s</sub> (mm)	Z	S	A	D	Dz	L	l	g <sub>min</sub> (mm)	g <sub>max</sub> (mm)	b	z	Z <sub>L</sub> (Stk)	S <sub>L</sub>	M <sub>LF</sub> (Nm)	n <sub>max</sub> (min <sup>-1</sup> )		l*	m*		
<b>340</b>	290	600000	240000	180000	644	10	M36x80	770	835	690	530	187	2	112	98	10	30	M30x130	1550	593	80,5	1020	230		
	340	862000	344800	220000	700	12	M36x80	845	920	770	554	194	2	122	118	10	35	M30x130	1550	546	118	1250	235		
<b>380</b>	310	757000	302800	227100	768	12	M42x110	940	1030	850	616	210	4	144	124	12	32	M36x180	2500	497	206	1730	240		
	380	1198000	479200	255000	828	14	M42x110	1000	1100	900	694	245	4	154	128	14	36	M36x180	2500	461	302	2250	240		
<b>410</b>	350	980000	392000	294000	900	16	M42x110	1080	1180	980	742	267	4	154	130	14	40	M36x180	2500	424	439	2860	235		
	410	1430000	572000	340000	955	16	M42x110	1110	1210	1020	742	267	4	154	130	14	42	M36x180	2500	409	496	3000	235		
<b>440</b>	380	1410000	564000	423000																					
	440	1960000	784000	460000																					
<b>470</b>	410	1680000	672000	504000																					
	470	2300000	920000	690000																					
<b>500</b>	440	1860000	744000	558000																					
	500	2500000	1000000	750000																					

\* related to nominal size

**Order key ( product labeling )**

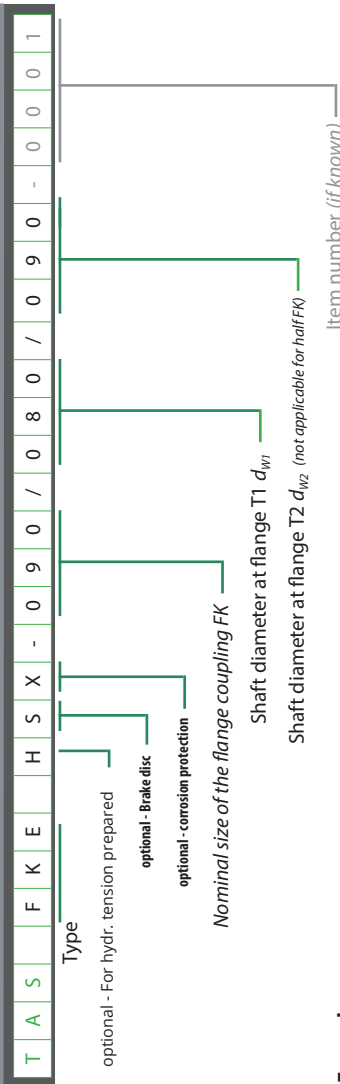

**Examples:**

- TAS FKE-090/085/095 Flange coupling in nominal size FKE = 090 / d<sub>W1</sub> = Ø85 / d<sub>W2</sub> = Ø95
- TAS FKE H-090/085/095 Flange coupling with preparation for hydraulic clamping tool in nominal size FKE = 090 / d<sub>W1</sub> = Ø85 / d<sub>W2</sub> = Ø95
- TAS FKE S-090/085/095 Flange coupling with brake disc in nominal size FKE = 090 / d<sub>W1</sub> = Ø85 / d<sub>W2</sub> = Ø95
- TAS FKE X-090/085/095 Flange coupling with extended corrosive protection in nominal size FKE = 090 / d<sub>W1</sub> = Ø85 / d<sub>W2</sub> = Ø95
- TAS FKE HX-090/085/095 Flange coupling with preparation for hydraulic clamping tool with extended corrosive protection in nominal size FKE = 090 / d<sub>W1</sub> = Ø85 / d<sub>W2</sub> = Ø95

**\*Additional options can be combined as required**

# Hydraulic clamping tool TAS HY for FKE H

## Short description:

The clamping tool is placed onto the front of one coupling half and is used to clamp the pressure ring of the coupling.

The tool is removed After locking the coupling half, and can be used for further couplings of the same nominal size.

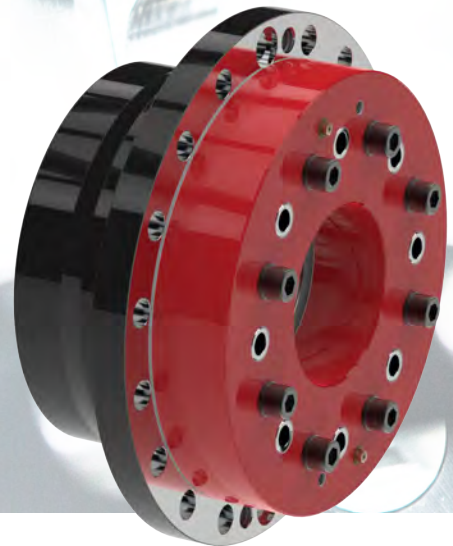

## Used symbols

Typ HY		Nominal size
z	[pcs.]	Number of screws at the hydraulic tool
D	[mm]	Outer diameter of the hydraulic tool
d	[mm]	Inner diameter of the hydraulic tool
b	[mm]	Width of the hydraulic tool without screws
m	[kg]	Weight
v	[l]	Oil volume

Oil type: HLP-46

Pos.	Designation
1	Tool HY
2	Main Screws
3	Flange half FKE H

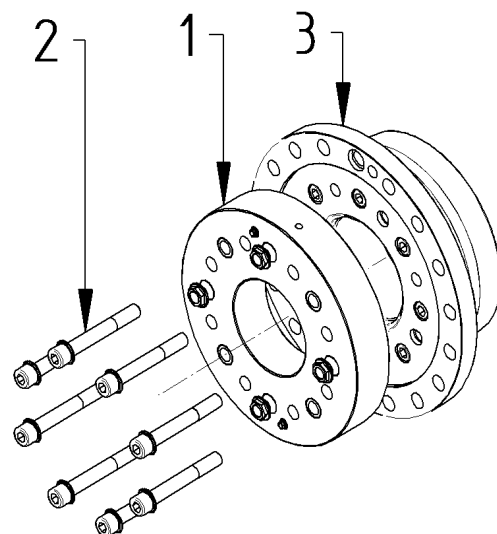
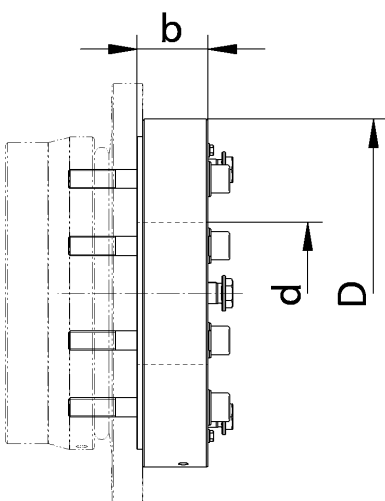

# Hydraulic clamping tool TAS HY for FKE H

Typ HY Designation	Nominal Size FKE	Screws		Compatible Pressure Rings				Dimensions			Mass	Oilvolume
		Size	Z (Pcs.)	Pressurering Size	Pressure ph (bar)	Pressurering	Pressure ph (bar)	D (Pcs.)	d (mm)	b (mm)	(kg)	v (l)
HY 150-71-185	<b>150</b>	M20x180	8	150-71-185	235	130-51-175	160	370	120	95	70	0,7
HY 165-71-195	<b>165</b>	M24x180	8	165-71-195	230	150-51-195	175	400	130	95	80	0,9
HY 180-71-220	<b>180</b>	M24x180	8	180-71-220	240	165-51-220	160	440	145	95	100	1,5
HY 200-71-240	<b>200</b>	M27x200	8	200-71-240	245	180-51-240	220	470	180	100	110	1,5
HY 220-71-260	<b>220</b>	M27x200	8	220-71-260	240	200-51-260	230	490	200	100	120	1,6
HY 240-71-280	<b>240</b>	M27x200	9	240-71-280	235	220-51-280	240	520	210	100	140	1,9
HY 260-71-320	<b>260</b>	M33x220	9	260-71-320	240	240-51-320	165	630	200	110	240	3,8
HY 290-71-340	<b>290</b>	M33x220	9	290-71-340	225	260-51-340	190	650	220	110	260	4,1
HY 310-71-360	<b>310</b>	M36x240	9	310-71-360	240	290-51-360	180	695	235	130	340	4,7
HY 340-71-390	<b>340</b>	M36x240	10	340-71-390	230	310-51-390	195	740	275	130	380	6,5
HY 380-71-420	<b>380</b>	M36x240	12	380-71-420	235	340-51-420	175	805	290	130	450	7,6
HY 410-71-460	<b>410</b>	M42x260	12	410-71-460	240	380-51-460	190	875	325	130	530	9,8
HY 440-71-500	<b>440</b>	M42x260	14	440-71-500	240	410-51-500	180	955	345	140	680	12,6
HY 470-71-560	<b>470</b>	M42x260	16	470-71-560	235	440-51-560	185	1050	390	140	820	15,0
HY 500-71-590	<b>500</b>	M42x260	16	500-71-590	235	470-51-590	215	1075	425	140	840	15,4

One additional seal kit is included as well as clamping screws and if necessary adapters for pressure rings of the light series 51.



# Connecting Flange AFS

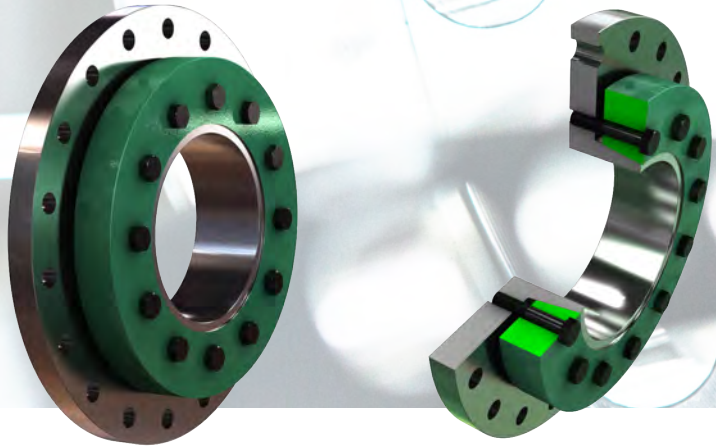
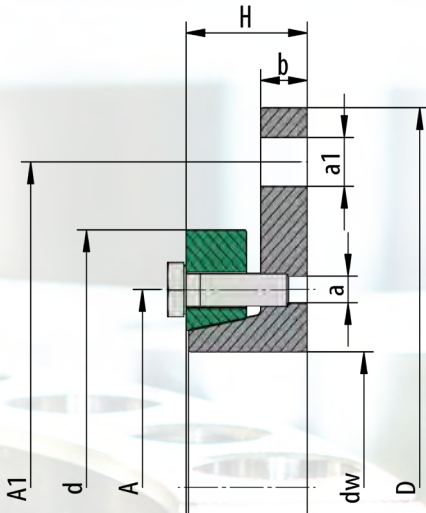

## Used Symbols

$d_w$	[mm]	Shaft diameter
$D$	[mm]	Outer diameter of the connecting flange
$M_{t \max}$	[Nm]	max transmittable torque
$H$	[mm]	Width of the connecting flange
$d$	[mm]	Outer diameter disc D
$A$	[mm]	Pitch circle diameter disc D
$A_1$	[mm]	Pitch circle diameter flange
$b$	[mm]	Width of the flange
$Z$		Number of screws disc D
$S$		Size
$M_A$	[Nm]	Required tightening torque
$S/a$		Number/ Size bores of the flange

## Design of the connecting flange

Alternative versions with centering, tapped holes and additional sizes on request.

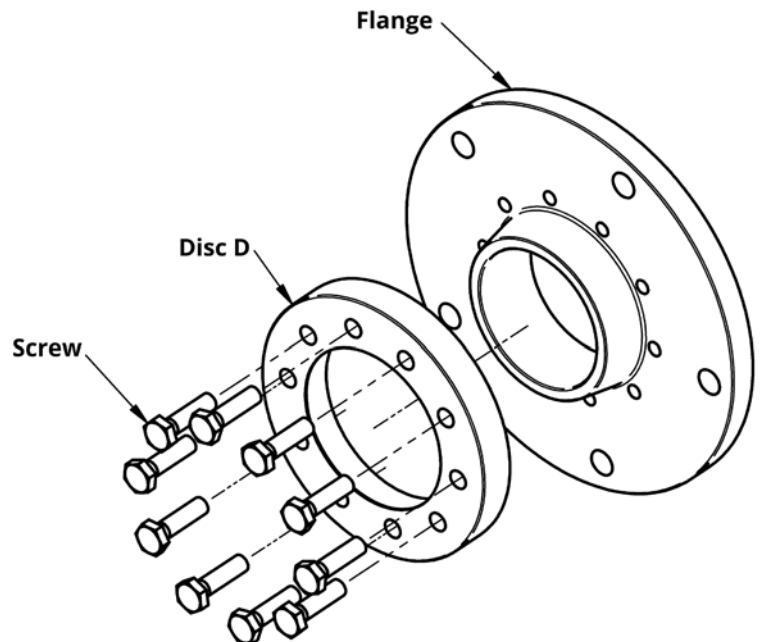

Example: AFS-200/470

# Connecting Flange AFS

$d_w$ mm	$D$ mm	$M_{t,max}$ Nm	$H$ mm	$d$ mm	$A$ mm	$Z$ Pcs	$S$	$M_A$ Nm	$A_1$ mm	$S/a$	$M_A$ Nm	$b$ mm	Weight kg
<b>30</b>	<b>105</b>	310	23	70	54	6	M6 x 020	12	90	4/6,6	12	8	1,00
<b>35</b>	<b>110</b>	450	23	75	59	7	M6 x 020	12	95	5/6,6	12	8	1,1
<b>40</b>	<b>130</b>	645	26	85	64	8	M6 x 022	12	110	4/9	30	10	1,3
<b>45</b>	<b>135</b>	850	26	90	68	9	M6 x 022	12	115	4/9	30	10	1,4
<b>50</b>	<b>140</b>	1100	27	95	73	10	M6 x 025	12	120	5/9	30	10	1,7
<b>55</b>	<b>150</b>	1375	27	105	78	11	M6 x 025	12	130	5/9	30	10	1,9
<b>60</b>	<b>155</b>	1725	28	110	84	12	M6 x 025	12	135	6/9	30	10	2,0
<b>65</b>	<b>170</b>	1940	30	125	95	7	M8 x 030	30	150	7/9	30	10	2,6
<b>70</b>	<b>180</b>	2500	30	135	100	8	M8 x 030	30	160	8/9	30	10	3,1
<b>75</b>	<b>195</b>	3000	34	140	105	9	M8 x 030	30	170	6/11	59	12	3,6
<b>80</b>	<b>200</b>	3650	34	145	110	10	M8 x 030	30	175	7/11	59	12	4,1
<b>85</b>	<b>210</b>	4150	37	155	118	11	M8 x 035	30	185	7/11	59	12	4,8
<b>90</b>	<b>215</b>	4950	37	160	123	12	M8 x 035	30	190	8/11	59	12	5,4
<b>100</b>	<b>235</b>	7350	40	180	138	10	M10 x 040	59	210	10/11	59	12	5,7

# AF Series 12

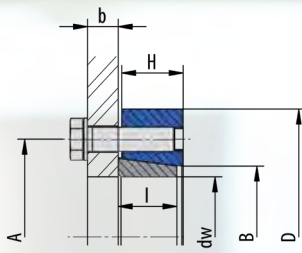

Model A

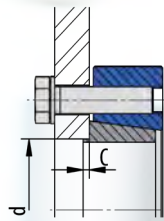

Model AB

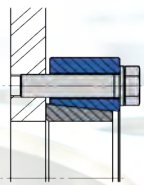

Model C

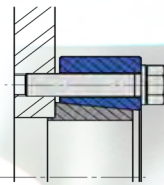

Model BC

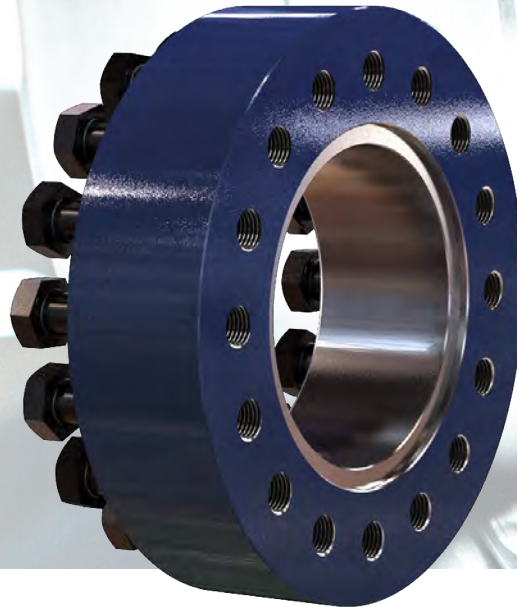

## Used symbols

Typ		Nominal size
$d_w$	[mm]	Shaft diameter
$M_{t \max}$	[Nm]	Max transmittable torque
D	[mm]	Outer diameter
I	[mm]	Length of the bush
H	[mm]	Width of the external clamping element
A	[mm]	Pitch circle diameter
C	[mm]	Length of the centering
d	[mm]	Diameter of the centering
B	[mm]	Attachment size
<b>Screws</b>		
Z		Number of screws
S		Size of screws
$M_A$	[Nm]	Required tightening torque

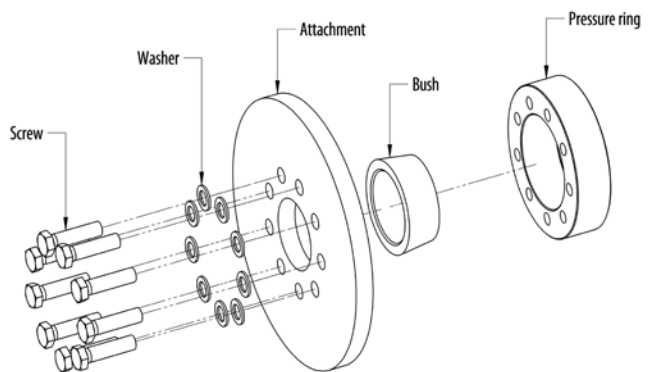

Example: **AF-60-12-60 A**

## Design of the external clamping element

$d < \text{Ø}125$ -pressure rings lightly oiled  
 $d \geq \text{Ø}125$ -pressure rings painted

### Applies to all types:

$b > 1,4 \times \text{Screw diameter}$

From M10 with washers

## Details of the fit

Shaft:

up to  $d_w$  150mm H7 / h6  
 from  $d_w$  155mm H7 / g6

Centring:

up to d 150mm H7 / h6  
 from d 155mm H7 / g6

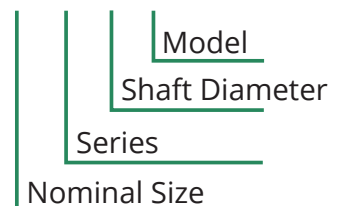



# AF Series 12

Type	$d_w$ mm	$Mt_{max}$ Nm	D mm	I mm	H mm	A mm	C mm	d mm	B mm	Z Pcs.	S	Class	Ma Nm	Weight kg
AF-10	11	20	39	9	10	25	1,5	12	13	3	M6x18	10.9	12	0,1
	10	20												
	9	20												
AF-12	13	50	44	12	13	28	1,5	14	16	3	M6x20	10.9	12	0,1
	12	50												
	11	50												
AF-15	16	130	52	14	15	36	2	18	21	3	M8x25	10.9	29	0,2
	15	130												
	14	130												
AF-20	20	200	60	16	17	42	2	22	25	3	M8x30	10.9	29	0,3
	18	200												
	16	200												
AF-25	25	340	70	18	19	48	2	27	31	5	M8x30	10.9	29	0,4
	22	340												
	20	340												
AF-30	30	550	76	20	21	56	2	32	35	6	M8x35	10.9	29	0,6
	28	550												
	25	550												
AF-40	40	1060	96	24	25	70	3	43	47	6	M10x35	10.9	58	1,2
	35	1060												
	30	1060												
AF-50	50	2200	112	29	30	84	3	53	58	7	M12x45	10.9	100	2
	45	1800												
	40	1000												
AF-60	60	3230	120	32	34	94	3	63	66	9	M12x50	10.9	100	2,3
	55	3230												
	50	2300												
AF-70	70	5800	148	38	40	112	4	74	79	8	M16x60	10.9	240	4,2
	65	5800												
	60	4500												
AF-80	80	8640	170	42	44	130	4	84	94	9	M16x65	10.9	240	6,1
	75	8640												
	70	6900												
AF-90	90	12000	185	48	50	144	4	94	104	12	M16x70	10.9	240	8
	85	12000												
	80	10700												
AF-100	100	15800	197	52	54	156	4	104	113	14	M16x75	10.9	240	9,5
	95	15800												
	90	15800												

# AF Series 22

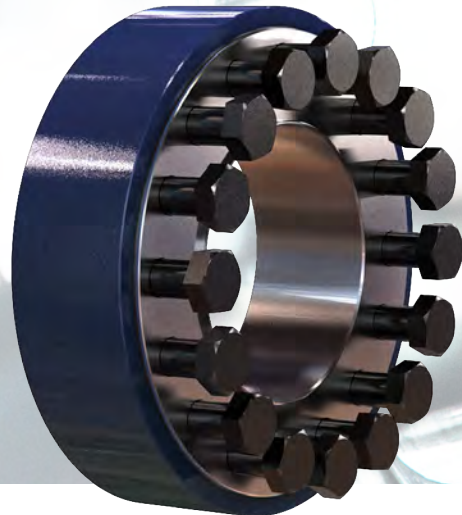
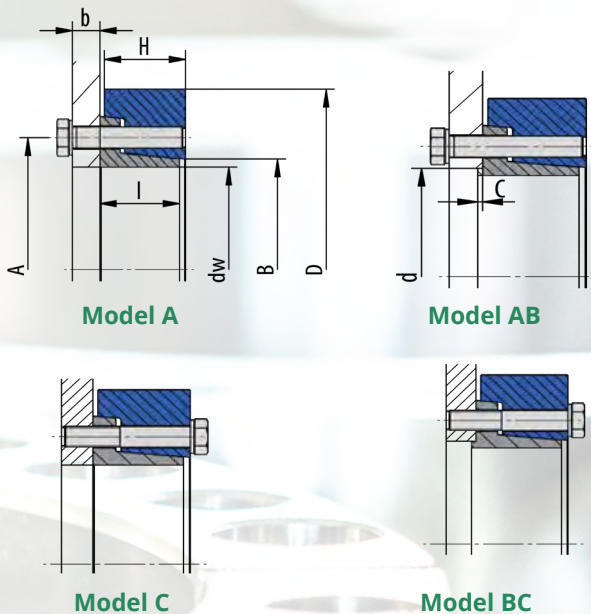

## Used symbols

Typ		Nominal size
$d_w$	[mm]	Shaft diameter
$M_{t \max}$	[Nm]	Max transmittable torque
D	[mm]	Outer diameter
I	[mm]	Length of the bush
H	[mm]	Width of the external clamping element
A	[mm]	Pitch circle diameter
C	[mm]	Length of the centering
d	[mm]	Diameter of the centering
B	[mm]	Attachment size
<b>Screws</b>		
Z		Number of screws
S		Size of screws
$M_A$	[Nm]	Required tightening torque

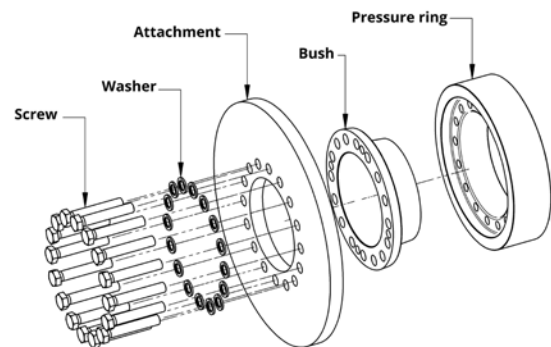

Example: **AF-60-22-60 A**

## Design of the external clamping element

$d < \varnothing 125$ -pressure rings lightly oiled  
 $d \geq \varnothing 125$ -pressure rings painted

**Applies to all types:**  
 $b > 1,4 \times$  Screw diameter

From M10 with washers

## Details of the fit

Shaft:  
 up to  $d_w$  150mm H7 / h6  
 from  $d_w$  155mm H7 / g6

Centring:  
 up to d 150mm H7 / h6  
 from d 155mm H7 / g6

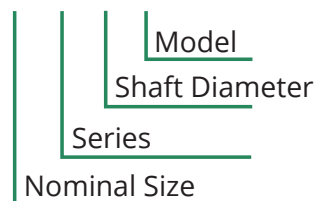

# AF Series 22

Typ	$d_w$ mm	$Mt_{max}$ Nm	D mm	I mm	H mm	A mm	C mm	d mm	B mm	Z Pcs.	S	Class	Ma Nm	Weight kg
AF-12	12	50	35	10	16	24	1,5	14	13	3	M6x20	10.9	12	0,1
	11	50												
AF-14	14	70	38	10	16	26	1,5	16	15	3	M6x20	10.9	12	0,1
	13	70												
AF-16	16	80	41	13,5	20	28	2	18	17	3	M6x25	10.9	12	0,1
	15	80												
AF-18	18	130	44	13,5	20	30	2	20	19	4	M6x25	10.9	12	0,1
	17	130												
AF-20	20	140	47	13,5	20	32	2	22	21	4	M6x25	10.9	12	0,2
	19	140												
AF-25	25	200	50	17	17	36	2	27	26	5	M6x30	10.9	12	0,2
	24	200												
	22	200												
AF-30	30	300	60	18	19	44	3	32	32	6	M6x30	10.9	12	0,3
	28	300												
	26	300												
AF-35	36	500	72	20	21	52	3	38	38	5	M8x35	10.9	29	0,5
	35	500												
	32	450												
AF-40	44	750	80	22	23	61	3	46	47	6	M8x35	10.9	29	0,7
	40	750												
	38	720												
AF-50	50	1300	90	24	25	68	3	53	53	8	M8x40	10.9	29	0,9
	45	1300												
	42	1000												
AF-55	55	1600	100	26	27	72	3	58	58	8	M8x40	10.9	29	1,2
	52	1600												
	45	1600												
AF-60	62	2000	110	26	27	80	3	63	66	9	M8x40	10.9	29	1,4
	60	2000												
	50	2000												
AF-70	70	2100	115	26	27	86	4	74	72	9	M8x40	10.9	29	1,5
	65	2100												
	60	2100												
AF-80	80	4000	141	28	29	100	4	84	82	10	M10x45	10.9	58	2,5
	75	4000												
	70	4000												
AF-90	90	5700	155	34	35	114	4	94	94	12	M10x50	10.9	58	3,6
	85	5700												
	80	5700												

# AF Series 22

Type	$d_w$ mm	$Mt_{max}$ Nm	D mm	I mm	H mm	A mm	C mm	d mm	B mm	Z Pcs.	S	Class	Ma Nm	Weight kg
AF-100	100	8400	170	39	40	124	4	104	104	12	M12x60	10.9	100	4,6
	95	8400												
	90	8400												
AF-110	110	9200	185	45	46	136	5	116	114	12	M12x70	10.9	100	6,2
	105	9200												
	100	9200												
AF-125	125	21000	215	48	50	160	5	126	134	12	M16x75	10.9	240	8,8
	120	21000												
	115	21000												
AF-140	140	26000	230	52	54	176	5	146	146	14	M16x80	10.9	240	11
	135	26000												
	130	26000												
AF-155	160	31000	263	54	55	192	5	166	162	15	M16x80	10.9	240	15
	155	31000												
	150	31000												
AF-170	170	36000	290	61	62	204	5	176	175	16	M16x90	10.9	240	21
	165	36000												
	160	36000												
AF-180	180	43000	300	61	62	218	5	186	185	18	M16x90	10.9	240	22
	175	43000												
	170	43000												
AF-190	190	60000	320	77	78	232	5	196	195	15	M20x110	10.9	470	31
	185	60000												
	180	60000												
AF-200	200	67000	340	75	78	246	5	206	209	16	M20x110	10.9	470	35
	195	67000												
	190	67000												
AF-220	220	93000	370	95	96	278	5	226	230	14	M24x130	10.9	820	53
	210	93000												
	200	93000												
AF-240	240	117000	405	98	100	296	5	246	248	16	M24x140	10.9	820	64
	230	117000												
	220	117000												
AF-260	260	126000	430	106	106	318	5	266	266	16	M24x150	10.9	820	80
	250	126000												
	240	126000												
AF-280	280	151000	460	118	118	340	5	286	288	18	M24x160	10.9	820	95
	270	151000												
	260	151000												
AF-300	300	178000	485	125	126	360	5	306	309	20	M24x170	10.9	820	110
	290	178000												
	280	178000												
AF-320	320	248000	520	125	126	380	5	330	328	20	M27x170	10.9	1210	134
	300	248000												
	280	248000												



# AF Series 22

Type	$d_w$ mm	$Mt_{max}$ Nm	D mm	I mm	H mm	A mm	C mm	d mm	B mm	Z Pcs.	S	Class	Ma Nm	Weight kg
AF-340	340	275000	570	134	136	402	5	350	351	21	M27x180	10.9	1210	180
	320	275000												
	300	275000												
AF-360	360	290000	590	142	144	424	8	370	367	21	M27x180	10.9	1210	200
	340	290000												
	320	290000												
AF-390	390	363000	630	146	148	458	8	400	398	20	M30x190	10.9	1640	222
	370	363000												
	350	363000												
AF-420	420	407000	650	166	168	490	8	430	424	21	M30x210	10.9	1640	263
	400	407000												
	380	407000												
AF-440	440	426000	670	174	176	512	8	450	448	21	M30x220	10.9	1640	309
	420	426000												
	400	426000												



# AF Series 23

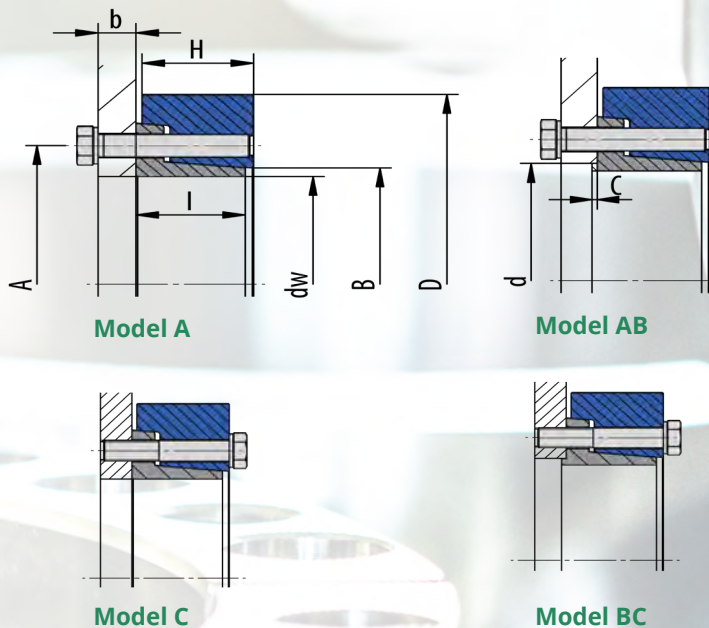

## Used symbols

Typ		Nominal size
$d_w$	[mm]	Shaft diameter
$M_{t \max}$	[Nm]	Max transmittable torque
D	[mm]	Outer diameter
I	[mm]	Length of the bush
H	[mm]	Width of the external clamping element
A	[mm]	Pitch circle diameter
C	[mm]	Length of the centering
d	[mm]	Diameter of the centering
B	[mm]	Attachment size
<b>Screws</b>		
Z		Number of screws
S		Size of screws
$M_A$	[Nm]	Required tightening torque

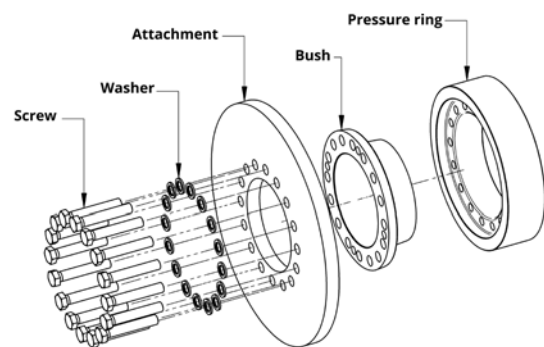

Example: **AF-60-23-60 A**

## Design of the external clamping element

$d < \varnothing 125$ -pressure rings lightly oiled  
 $d \geq \varnothing 125$ -pressure rings painted

## Applies to all types:

$b > 1,4 \times$  Screw diameter

From M10 with washers

## Details of the fit

Shaft:

up to  $d_w$  150mm H7 / h6  
 from  $d_w$  155mm H7 / g6

Centring:

up to d 150mm H7 / h6  
 from d 155mm H7 / g6

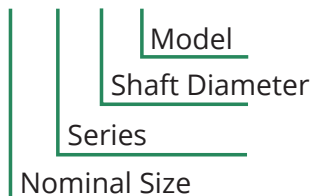

# AF Series 23

Type	$d_w$ mm	$Mt_{max}$ Nm	D mm	I mm	H mm	A mm	C mm	d mm	B mm	Z Pcs.	S	Class	Ma Nm	Weight kg
AF-50	50	3300	115	29	30	84	3	53	58	7	M12x45	10.9	100	2
	45	2200												
	40	1400												
AF-60	60	4700	120	32	34	94	3	63	66	9	M12x50	10.9	100	2,2
	55	3500												
	50	2300												
AF-70	70	9400	148	38	40	112	4	74	79	8	M16x60	10.9	240	3,9
	65	7600												
	60	5800												
AF-80	80	12000	167	43	46	130	4	84	94	9	M16x65	10.9	240	5,4
	75	10000												
	70	8000												
AF-90	90	18000	185	48	50	144	4	94	104	12	M16x70	10.9	240	7,4
	85	15000												
	80	12000												
AF-100	100	23000	197	52	54	156	4	104	114	14	M16x75	10.9	240	8,7
	95	19000												
	90	16000												
AF-110	110	27000	215	56	58	166	5	116	124	10	M20x90	10.9	470	11
	105	26000												
	100	22000												
AF-120	120	43000	230	62	65	186	5	126	134	14	M20x90	10.9	470	13,6
	115	38000												
	110	33000												
AF-140	140	56000	290	75	76	216	5	146	160	16	M20x100	10.9	470	29
	130	50000												
	120	39000												
AF-160	160	77000	320	82	83	234	5	166	180	14	M24x110	10.9	820	36,1
	150	77000												
	140	64000												
AF-180	180	104000	340	91	94	276	5	186	205	16	M24x130	10.9	820	45,3
	170	101000												
	160	85000												
AF-200	200	144000	370	95	96	290	5	206	226	16	M27x140	10.9	1210	53,7
	190	133000												
	180	114000												
AF-220	220	178000	405	96	96	320	5	226	246	18	M27x140	10.9	1210	64,3
	210	178000												
	200	159000												
AF-240	240	211000	430	109	110	340	5	246	267	20	M27x150	10.9	1210	81
	230	211000												
	220	211000												
AF-260	260	232000	460	118	118	356	5	286	289	21	M27x160	10.9	1210	109,4
	250	234000												
	240	234000												

# AF Series 23

Type	$d_w$ mm	$Mt_{max}$ Nm	D mm	I mm	H mm	A mm	C mm	d mm	B mm	Z Pcs.	S	Class	Ma Nm	Weight kg
<b>AF-280</b>	280	234000	485	124	125	360	5	306	304	21	M27x180	10.9	1210	116
	270	234000												
	260	234000												
<b>AF-300</b>	300	247000	520	128	126	380	5	330	315	21	M27x180	10.9	1210	141
	290	247000												
	280	247000												
<b>AF-320</b>	320	299000	550	134	136	402	5	350	336	24	M27x180	10.9	1210	161
	310	299000												
	300	299000												
<b>AF-340</b>	340	315000	570	140	143	424	8	370	368	24	M27x180	10.9	1210	177
	330	315000												
	320	315000												
<b>AF-360</b>	360	410000	610	144	147	454	8	400	383	24	M30x190	10.9	1640	210
	350	410000												
	340	410000												
<b>AF-390</b>	390	439000	630	164	167	486	8	430	428	24	M30x200	10.9	1640	250
	380	439000												
	360	439000												
<b>AF-420</b>	420	457000	670	172	175	506	10	450	440	24	M30x220	10.9	1640	292
	410	457000												
	390	457000												
<b>AF-440</b>	440	562000	700	172	175	534	10	470	468	28	M30x220	10.9	1640	318
	420	562000												
	400	562000												